

# **REVISION NO. 2 - GEOTECHNICAL REPORT**

**The Catherine and Isiah Leggett Building  
Montgomery College  
7600 Takoma Avenue  
Takoma Park, Maryland**

Schnabel Engineering DC, Inc.  
CBE License No. L22053052020

Schnabel Reference: 18C41041  
June 24, 2019



**Schnabel Engineering DC**



4200 Wisconsin Avenue, NW, Suite LL9 / Washington, DC / 20016  
CBE License No. L22053052020

June 24, 2019

Mr. Kevin Johnson, AIA, LEED AP  
SmithGroup  
1700 New York Avenue NW, Suite 100  
Washington, DC 20006

**Subject: Project 18C41041, Revision No. 2 - Geotechnical Engineering Report, The Catherine and Isiah Leggett Building, Montgomery College, 7600 Takoma Ave, Takoma Park, Maryland**

Dear Mr. Johnson:

**SCHNABEL ENGINEERING DC, INC.** is pleased to submit our revised geotechnical engineering report for this project. This study was performed in accordance with our proposal dated January 18, 2018, as authorized by you via email of August 5, 2018, and our Revision No. 1 proposal dated May 2, 2019. This report supersedes the final reports issued on December 11, 2018, and January 23, 2019, and the draft Revision No. 2 report issued on May 21, 2019. We appreciate the opportunity to be of service for this project. Please call us if you have any questions regarding this report.

Sincerely,

**SCHNABEL ENGINEERING DC, INC.**

A handwritten signature in blue ink that reads 'J. Bentel'.

Joan Bentel, PE  
Associate

Bill Khouri, PE  
Principal



*"Professional Certification. I hereby certify that these documents were prepared or approved by me and that I am a duly licensed professional engineer under the laws of the State of Maryland, License No. 17793, Expiration Date: 5-12-2020."*

MK:SO:JB:BK:is:jb

\\SEDC-FS\PROJECTS\2018\PROJECTS\18C41041 - MC MATH & SCIENCE CENTER\03-SE PRODUCTS\03-REPORTS\02-FINAL\FINAL GEOTECHNICAL REPORT\_REV. 2\_062419.DOCX

[schnabelDC.com](http://schnabelDC.com)

T/ 202-677-4120  
F/ 202-677-4121

REVISION NO. 2 - GEOTECHNICAL ENGINEERING REPORT  
THE CATHERINE AND ISIAH LEGGETT BUILDING  
TAKOMA PARK, MARYLAND

TABLE OF CONTENTS

<b>1.0</b>	<b>EXECUTIVE SUMMARY .....</b>	<b>1</b>
<b>2.0</b>	<b>SCOPE OF SERVICES .....</b>	<b>3</b>
<b>3.0</b>	<b>DESCRIPTION OF SITE AND PROPOSED CONSTRUCTION .....</b>	<b>4</b>
3.1	Site Description .....	4
3.2	Proposed Construction .....	4
<b>4.0</b>	<b>SUBSURFACE EXPLORATION PROGRAM .....</b>	<b>5</b>
4.1	Subsurface Exploration and Field Testing .....	5
4.2	Laboratory Testing .....	6
<b>5.0</b>	<b>SITE GEOLOGY AND SUBSURFACE CONDITIONS .....</b>	<b>7</b>
5.1	Site Geology.....	7
5.2	Generalized Subsurface Stratigraphy .....	7
5.3	Groundwater .....	9
5.4	In-Situ Infiltration Test Results .....	10
5.5	USDA Classification and Correlated Infiltration Rates .....	11
5.6	Seismic Site Classification .....	12
<b>6.0</b>	<b>SITE GRADING AND EARTHWORK .....</b>	<b>13</b>
6.1	Preparation of Subgrades to Receive Compacted Fill .....	13
6.2	Compacted Fill .....	14
6.3	Fill Settlement .....	15
<b>7.0</b>	<b>FOUNDATION RECOMMENDATIONS .....</b>	<b>16</b>
7.1	Spread Footings.....	16
<b>8.0</b>	<b>FLOOR SLAB RECOMMENDATIONS .....</b>	<b>17</b>
<b>9.0</b>	<b>RETAINING STRUCTURE RECOMMENDATIONS .....</b>	<b>18</b>
9.1	Below-Grade Walls .....	18
9.2	Backfill for Below-Grade Walls.....	18

<b>10.0</b>	<b>SUBDRAINAGE RECOMMENDATIONS.....</b>	<b>19</b>
10.1	Subdrainage for Below-Grade Walls.....	19
10.2	Basement Subdrainage .....	19
<b>11.0</b>	<b>CONSTRUCTION CONSIDERATIONS .....</b>	<b>21</b>
11.1	Site Grading and Earthwork.....	21
11.2	Foundations .....	21
11.3	Construction Dewatering.....	21
11.4	Subdrainage.....	22
11.5	Engineering Services During Construction .....	22
<b>12.0</b>	<b>GENERAL SPECIFICATION RECOMMENDATIONS.....</b>	<b>23</b>
<b>13.0</b>	<b>LIMITATIONS .....</b>	<b>24</b>

#### LIST OF FIGURES

- Figure 1: Site Vicinity Map
- Figure 2: Approximate Boring Location Plan
- Figure 3: Lateral Earth Pressure Diagram for Design of Below-Grade Walls
- Figure 4: Subdrainage Details

#### LIST OF TABLES

- Table 4.1: Summary of Pressuremeter Tests Results
- Table 5.1: Summary of In-Situ Infiltration Test Results
- Table 5.2: USDA Textural Classification and Minimum Infiltration Rates
- Table 6.1: Estimated Elevation of Suitable Compacted Fill Subgrades

#### APPENDICES

- Appendix A: Subsurface Exploration Data
- Appendix B: In-Situ Test Results
- Appendix C: Soil Laboratory Test Data

## **1.0 EXECUTIVE SUMMARY**

This report presents the results of the geotechnical investigation and testing conducted by Schnabel Engineering DC, Inc. (SEDC) for the proposed Catherine and Isiah Leggett Building for SmithGroup. Based on our evaluation of the subsurface conditions revealed by our field investigation and the project data furnished to us, we have developed the following summary of our major conclusions and recommendations. Detailed recommendations are presented in the body of the report.

- Ten soil test borings were advanced in the general area of the proposed building and five soil borings were advanced at proposed stormwater management locations (one of the test building borings also served as a stormwater boring, SB-05/SWM-4) in 2018. Two additional soil test borings were advanced in May 2019. The subsurface investigations revealed that the site is underlain by terrace deposits (Strata B1 and B2) overlaying residual soils (Strata C1, C2, and D). Existing fill was also encountered and extended between 1.2 ft to 6 ft below surface grades in the majority of the borings, except at borings SB-08 and SB-10. At these locations, deeper fill was present and extended 13.5 ft to 23.5 ft below surface grades, respectively.
- The subject site is currently occupied by Falcon Hall with the lowest level at predominately EL +307 (ft) and some spaces with a lowest level at EL +302 (ft), and the Science South Building with a lowest level at EL +326 (ft). Both buildings will be demolished in their entirety and the buildings' foundation systems will be completely removed. Cuts of up to about 15 ft are expected, and the majority of the fill that was encountered in the borings will be removed as part of the demolition. At boring SB-10, where fill extended to EL +302.9 (ft), the fill material is believed to be backfill of the present-day building. Boring SB-10 currently lies outside of the proposed building footprint and our recommendations have been tailored with this consideration.
- To reach the proposed lowest level of the new Catherine and Isiah Leggett Building at EL +320 (ft), up to about 15 ft to 18 ft of new compacted structural fill will need to be placed. Due to the large thickness of new fill being placed, settlement plates will need to be installed and the fill monitored to ensure that settlement has dissipated before the building can be constructed. Additional details are included herein.
- Considering a maximum column load of about 200 kips to 300 kips, we recommend the new building be supported on spread footings founded on firm natural soils of Strata B1, B2, C1, or C2 or on compacted structural fill. In areas where existing natural soil is loose/soft or existing fill material is present, these materials should be removed and replaced with compacted structural fill or lean concrete. Spread footings can be designed for an allowable soil bearing pressure of 3,000 psf as discussed in detail in the report.
- The proposed floor slabs should be supported on suitable natural soils of Strata B1, B2, C1, and C2 or compacted structural fill. A modulus of subgrade reaction,  $k$ , of 100 kcf (kips per cubic foot) should be used in the design of floor slabs.

**SmithGroup**  
**The Catherine and Isiah Leggett Building**

- We evaluated the Seismic Site Class for this project according to the International Building Code (IBC) Section 1613 2015. Our analysis indicates Site Class D for this location. This Site Class was evaluated based on the Standard Penetration Test (SPT) values.
- Building walls that extend below-grade need to be designed to withstand lateral earth pressures. Additional details are provided herein.
- Subdrainage below the floor slab and behind below-grade walls will be required. Dewatering during construction will also be required. Additional details are provided herein.

We are providing this executive summary solely for purposes of overview. Any party that relies on this report must read the full report. This executive summary omits several details, any one of which could be very important to the proper application of the report.

## **2.0 SCOPE OF SERVICES**

Our proposal dated January 18, 2018, and Revision No. 1 proposal dated May 2, 2019, defines the scope of services for this project. The scope of services includes the following:

- Advancing twelve (12) soil test borings to depths between 40 ft and 55 ft each, five soil test borings to depths between 15 ft and 16 ft each, and conducting pressuremeter testing at two (2) of the building borings.
- Conducting falling head infiltration testing at six locations.
- Preparation of a report consisting of:
  - Project and site description, including relevant information relating to nearby foundations and structures, etc.
  - A boring location plan, indicating boring locations referenced to actual physical features and proposed locations of structures.
  - Boring logs with soil/rock description, classification, and depth of fill, groundwater observations, and any other observations made during the exploration, including the ground surface elevations at boring locations.
  - An estimate of subsurface conditions and groundwater levels within the area explored.
  - Foundation requirements including a net allowable soil bearing pressure, bearing grades and estimated settlements for spread footings.
  - Recommendations for floor slab support, including a recommended modulus of subgrade reaction for use in slab design.
  - Earthwork recommendations for the construction of load-bearing fill including an assessment of site soils for use as fill, subgrade preparation, and compaction criteria.
  - Recommended Seismic Site Class in accordance with IBC 2015 for use in foundation design based on an extrapolation of data collected in the subsurface exploration.
  - Recommended static earth pressures, subdrainage and backfill requirements for basement walls, loading dock walls or retaining walls, if necessary.
  - Recommendations regarding permanent subdrainage design and installation, if necessary.
  - Recommendations regarding building area surcharging requirements due to the placement of new compacted structural fill.
  - Construction considerations related to the implementation of our recommendations.

### **3.0 DESCRIPTION OF SITE AND PROPOSED CONSTRUCTION**

#### **3.1 Site Description**

We understand that the project will consist of constructing The Catherine and Isiah Leggett Building at the Montgomery College Takoma Park/Silver Spring Campus in Takoma Park, Maryland. The project site is bounded by Fenton Street to the south and west, Takoma Avenue to the east, and New York Avenue to the north. A Site Vicinity Map is included as **Figure 1**.

Areas to be improved are currently asphalt lots, the Falcon Hall and Science South academic buildings, tennis courts, and landscaped grass areas between academic buildings. We understand that the lowest level elevation for the Science South building is at elevation EL +326 (ft), and the lowest level elevation for Falcon Hall is at approximate elevation EL +307 (ft). Both of these buildings are believed to be supported on spread footings. Existing grades in the area of the proposed building footprint range from about EL +315 (ft) to about EL +334 (ft).

We obtained the site information from our site visits and from the information provided by your office. The topographic information was supplied by A. Morton Thomas and Associates.

#### **3.2 Proposed Construction**

The proposed building will be located along the east portion of the Takoma Park/Silver Spring Campus in the area where present-day Falcon Hall, the Science South Building, Staff Parking Lot E1, and the tennis courts are situated. We understand that existing Falcon Hall and the Science South Building will be demolished in their entirety to provide an adequate footprint for the proposed building. The new building will be 134,000 net square feet in area and will extend into the area currently occupied by Lot E1, abutting the Fenton Street campus boundary and the Science North Building.

The proposed building will be two to three levels and will have up to one level below grade with a lowest level at EL +320 (ft). Based on the existing grades, we anticipate cuts of about 2 ft to 15 ft will be required to reach the lowest level elevation. Upon demolishing Falcon Hall, with lowest level ranging between EL +307 (ft) and EL +302 (ft), compacted structural fill of up to 18 ft will need to be placed to reach the proposed lowest level of the new building. We understand that the maximum column load will be about 200 kips to 300 kips and typical column spacing will be 30 ft by 30 ft.

The lowest level elevation and building layout information was supplied by your office and the structural loading information was provided by Cagley and Associates.



#### 4.0 SUBSURFACE EXPLORATION PROGRAM

We performed two subsurface explorations and in-situ testing to identify the subsurface stratigraphy underlying the site and to evaluate the geotechnical properties of the materials encountered. Our explorations included drilling 17 standard penetration test (SPT) borings and conducting pressuremeter testing. Additionally, falling head infiltration testing was conducted at six locations selected by your Civil Engineer. **Appendix A** contains the results of our exploration and the borings logs.

#### 4.1 Subsurface Exploration and Field Testing

##### 4.1.1 Test Borings

Our subcontractor, Recon Drilling, drilled 15 soil test borings under our observation between August 6, 2018, and August 14, 2018. The May 2019 borings (Boring A and Boring B) were drilled by Connelly and Associates on May 15, 2019, and May 16, 2019. The Standard Penetration Test (SPT) was performed at selected depths. Borings SB-01 through SB-10 were drilled to depths between 38.5 ft and 53.5 ft in the proposed building area. Boring A and Boring B were drilled to depths between 38.8 ft and 34.0 ft, respectively, in the proposed building area. Borings SWM-01 through SWM-06 were drilled to depths between 15 ft and 16 ft at the proposed infiltration areas.

Standard penetration testing was conducted at typical intervals from the ground surface to the bottom of each borehole. **Appendix A** includes specific observations, remarks, and logs for the borings, classification criteria, drilling methods, and sampling protocols. **Figure 2**, included at the end of this report, indicates the approximate test boring locations. Soil samples from the 2018 investigation have been disposed of. The soil samples for Boring A and Boring B will be retained for up to 45 days beyond the issuance of this report, unless you request other disposition.

##### 4.1.2 Pressuremeter Testing

We performed four in-situ pressuremeter tests, two tests in an offset boring location adjacent to boring SB-05/SWM-04 and another two tests within boring SB-06 to evaluate the strength and deformation characteristics of soils. Details of the pressuremeter tests and test results are included in **Appendix B**. It should be noted that results for only three of the tests are included in **Appendix B**; the fourth test indicated that the material was disturbed and the test results are unreliable. **Table 4.1** below summarizes the pressuremeter tests results.

**Table 4.1: Summary of Pressuremeter Tests Results**

Boring Number	Pressuremeter Test Depth (ft)	Stratum	Limiting Pressure (tsf)	Pressuremeter Modulus (tsf)
SB-05/SWM-4	14	D (Disintegrated Rock)	18	308
SB-06	24	C2 (Residual)	12	86
SB-06	27.5	C2 (Residual)	12	105

#### **4.1.3 Infiltration Testing**

To evaluate the feasibility for groundwater infiltration at the site, six in-situ falling head infiltration tests were performed on August 8, 2018, and August 10, 2018, within augered probe-holes drilled adjacent to borings SWM-1 through SWM-6. The in-situ infiltration tests were performed at a depth of about 6 ft below surface grades. The in-situ infiltration test procedure included placing a solid 5-inch diameter PVC pipe in the offset probe-holes then pre-soaking the bottom of each hole by placing 24 inches of water in the bottom of the pipe for a minimum of 24 hours. After the pre-soak period, and after replacing any water that may have dropped during the pre-soak period, the infiltration tests were performed, which consisted of monitoring the drop in the water level at 1-hour intervals for 4 hours. Following each 1-hour reading, water was added to the pipe to return the water level to 24 inches. The results of the infiltration testing are summarized in **Section 5.4**.

#### **4.2 Laboratory Testing**

Select jar samples collected during drilling were submitted for laboratory testing. The results are incorporated in the generalized subsurface stratigraphy section of the report and are included in **Appendix C**.

## 5.0 SITE GEOLOGY AND SUBSURFACE CONDITIONS

### 5.1 Site Geology

The geologic stratigraphy consists of sand and clay terrace deposits overlying residual soils. Terrace deposits are typically a result of river currents. The residual soils are derived from weathering of the bedrock at the site. The parent bedrock at the site is believed to be schist of the Wissahickon Formation. Fill and probable fill was also encountered at the site and is believed to be associated with past grading and development at the site. During our exploration, we encountered the following stratigraphy:

- Stratum A: Existing Fill and Probable Fill
- Stratum B1: Terrace Group Fine-Grained Deposits
- Stratum B2: Terrace Group Coarse-Grained Deposits
- Stratum C1: Fine-Grained Residual Soil
- Stratum C2: Coarse-Grained Residual Soil
- Stratum D: Disintegrated Rock

### 5.2 Generalized Subsurface Stratigraphy

We characterized the following generalized subsurface stratigraphy based on our subsurface exploration included in the **Appendix A**. The strata designations do not imply continuity of materials encountered elsewhere on site but reflect the general description and characteristics of the subsurface materials at the boring locations.

***Ground Cover: (Topsoil or Asphalt over Gravel Base)***

Between about 2 to 4 inches of topsoil, or 5 to 12 inches of asphalt over about 6 to 7 inches of gravel base, and 8 inches of concrete, was encountered at the ground surface of the boring locations. These depths may vary at other locations at the site.

***Stratum A: Fill and Probable Fill***

Below the ground cover materials, the borings encountered fill and probable fill soils generally consisting of sandy lean clay, sandy silt, silty sand, silty gravel with sand, and clayey sand, containing various amounts of gravel, roots, glass fragments, rock fragments, quartz fragments, brick fragments, asphalt, mica, and organics. Fill and probable fill was encountered in all borings, except for boring SWM-6. The borings indicated that fill material extended to depths ranging between 1.2 ft and 23.5 ft below existing grades. Based on the Standard Penetration Tests (SPTs), this stratum exhibits generally variable density and consistency. Three jar samples of Stratum A were laboratory tested. One jar was tested for moisture content, Atterberg limits, and gradation. The soil sample classified as sandy LEAN CLAY (CL) with a liquid limit of 41 and a plasticity index of 18. The amount of material passing through No. 200 sieve was 50.6 percent. The other two jar samples were tested for moisture content only. Moisture contents for the three samples ranged between 9.6 percent and 17.7 percent. SPT N-values within the fill layer ranged from 2 blows per foot (bpf) to 33 bpf with the majority of the N-values between 5 bpf and 15 bpf, indicating that the soil in this stratum is generally loose to medium dense and medium stiff to stiff.

***Stratum B1: Terrace Soil (Fine Grained)***

Below Stratum A, and interlayered with Stratum B2 soils, the majority of the borings encountered a fine grained terrace deposit consisting of yellowish brown, yellowish red, reddish brown, red, gray, light gray, and white sandy LEAN CLAY (CL), LEAN CLAY with sand (CL), gravelly LEAN CLAY with sand (CL), sandy LEAN CLAY with gravel (CL), and sandy FAT CLAY with gravel (CH), containing trace amounts of roots, mica, gravel, and cemented sand. The thickness of this layer ranged from 2 ft to 12 ft and extended to depths of up to 23.5 ft below existing grades. The unconfined compressive strength of this stratum was measured using a pocket penetrometer. Pocket penetrometer measurements ranged from 0.5 tsf to 4 tsf. Two jar samples were laboratory tested for moisture content, Atterberg limits, and gradation. Both samples classified as LEAN CLAY with sand (CL) and exhibited liquid limits of 39 and 40, and a plasticity index of 15. The amount of material passing through the No. 200 sieve was 81.5 to 83.2 percent. The moisture contents for these samples were 12 percent and 19 percent. Based on the SPT results, this stratum exhibits generally stiff to very stiff consistency (SPT values varied from 5 bpf to 27 bpf).

***Stratum B2: Terrace Soil (Coarse Grained)***

Below Stratum A, and interlayered with Stratum B1, all borings, except borings SB-05/SWM-4 and SWM-5, encountered a coarse-grained terrace deposit consisting of yellowish red, yellowish brown, reddish brown, brown, light brown, white, red, gray, black, and tan poorly graded SAND with clay and gravel (SP-SC), clayey GRAVEL (GC), clayey GRAVEL with sand (GC), clayey SAND (SC), clayey SAND with gravel (SC), poorly graded GRAVEL (GP), silty SAND (SM), and poorly graded SAND with silt (SP-SM). The thickness of Stratum B2 varied between 2 ft and 21 ft and extended to depths of up to 28.5 ft below existing grades. Six jar samples of Stratum B2 were tested. Five jars were tested for moisture content, Atterberg limits, and gradation, and one jar sample was tested for moisture content only. Three soil samples classified as clayey SAND (SC) and two samples classified as clayey SAND with gravel (SC). Liquid limits varied between 34 and 39 and the plasticity indices varied between 13 and 15. The amount of material passing through No. 200 sieve was between 15.5 percent and 31.7 percent. Moisture contents for these samples ranged between 7.4 percent and 17 percent. SPT N-values varied from 6 bpf to 68 bpf. The majority of N-values were between 10 bpf and 30 bpf indicating that the majority of this stratum is firm to medium dense.

***Stratum C1: Residual Soils (Fine Grained)***

Below Stratum B2, and interlayered with Stratum C2, borings SB-02, SB-08, SB-10, and Boring A encountered fine grained residual soils consisting of yellowish red, yellowish brown, gray, brown, and light red sandy LEAN CLAY (CL) and sandy ELASTIC SILT (MH). The thickness of Stratum C1 was about 5 ft and extended to depths of up to 33 ft below existing grades. Pocket penetrometer measurements ranged from 0.25 tsf to 2.5 tsf. One jar sample of Stratum C1 was tested for moisture content, Atterberg limits, and gradation. The soil sample classified as sandy LEAN CLAY (CL) with a liquid limit of 49 and a plasticity index of 25. The amount of material passing through No. 200 sieve was 55.9 percent and the moisture content for the soil sample was 22.9 percent. SPT N-values for this stratum varied from 6 bpf to 56 bpf indicating that the majority of this stratum is generally medium stiff to hard. A possible boulder or rock ledge was encountered within Stratum C1 in boring SB-02 at about 27 ft below surface grade.

***Stratum C2: Residual Soil (Coarse Grained)***

Below Strata B1 and B2, and interlayered with Stratum C1, borings SB-01 through SB-10, Boring A, Boring B, SWM-3, and SWM-5 encountered coarse-grained residual soil consisting of brown, gray, black, yellowish brown, bluish gray, reddish brown, greenish gray, light brown, light yellowish brown, and light yellowish red silty SAND (SM), clayey SAND (SC), and sandy SILT (ML). Rock fragments were encountered within some of the soil samples obtained from Stratum C2. The thickness of this stratum varied between 2 ft and 20 ft and extended to depths of up to 43.5 ft below existing grades. Three jar samples of Stratum C2 were tested, one of these jar samples was tested for moisture only. Two of the soil samples classified as clayey SAND (SC) and exhibited liquid limits of 46 and 47 and plasticity indices of 22 and 24. The amount of material passing through No. 200 sieve was 42.3 percent and 42.4 percent. Moisture contents for the three samples ranged between 20.9 percent and 29.3 percent. The SPT N-values varied from 4 bpf to 59 bpf. The majority of N-values were between 10 bpf and 50 bpf indicating that the majority of this stratum is loose to very dense.

***Stratum D: Residual (Disintegrated Rock)***

Below Stratum C1 and below and interlayered with Stratum C2, borings SB-01 through SB-10, Boring A, and Boring B encountered DISINTEGRATED ROCK sampling as silty sand and sandy silt, containing varying amounts of mica and rock fragments. Stratum D extended to depths of about 34ft to about 53.5 ft below existing grades, the maximum depth of the building borings. SPT values varied from 61 bpf to 50 blows with no penetration. Based on the SPT results, this stratum is generally very dense. Auger refusal was also encountered during drilling in Stratum D.

Residual soils are derived through the in-place physical and chemical weathering of the underlying rock. Disintegrated rock is defined as residual material with SPT N-values between 60 blows per foot and refusal. Refusal is defined as an N value of 100 blows for penetration of 2 inches or less.

The soil group symbol included on the boring logs in **Appendix A** and in the above-generalized subsurface stratigraphy represents the Unified Soil Classification System (USCS) group symbols and is based on visual identification of the soil samples collected at the site. Some variation can be expected between samples visually classified and samples classified in the laboratory.

### **5.3 Groundwater**

Groundwater was encountered during drilling at borings SB-01 through SB-07, SB-09, SB-10, Boring A, and SWM-1 at depths between 13 ft and 23.7 ft below existing grades, or between about EL +315 (ft) to EL +293.8 (ft). Upon completion of the drilling, prior to pulling augers, groundwater was observed between depths of 13.7 ft and 40 ft, or between about EL +312.5 (ft) and EL +290.7 (ft). After pulling augers, borings SB-02, SB-04, SB-08, SB-10, Boring A, and SWM-1 through SWM-6, were observed to be dry to the depth borings caved. After pulling augers, the groundwater was observed at SB-03, SB-05/SWM-4, SB-06, SB-07, and Boring B at depths between 6.8 ft and 27.9 ft or between EL +315.1 (ft) and EL +288.1 (ft). Boring sidewalls caved between depths of 1.3 ft and 33.5 ft, or between EL +326.4 (ft) and EL +288 (ft).

At borings SB-01 and SB-09, after casing was pulled, temporary, hand-slotted PVC pipe was installed in each boring. At these locations, after augers were pulled, groundwater was observed within the pipes at depths of 13.3 ft and 40.5 ft below existing grades, or between EL +319.7 (ft) and EL +279.3 (ft).

**SmithGroup**  
**The Catherine and Isiah Leggett Building**

All the 2018 boreholes and Boring A were left open and 24-hour groundwater readings were taken. Borings SB-02, SB-04, SWM-1 through SWM-3, SWM-6, and Boring A were dry to the depths of the borings sidewall cave-in, which ranged from 1.1 ft to 12.5 ft, or from about EL +326.9 (ft) to EL +318.63 (ft). After 24 hours, groundwater was observed in borings SB-03, SB-05/SWM-4, SB-06 through SB-8, SB-10, and SWM-5 between depths of 2.9 ft and 20.4 ft, or between EL +323.3 (ft) and EL +308.7 (ft). At these locations, the boring sidewalls caved at depths varying between 6.8 ft and 21.5 ft, or between about EL +315.3 (ft) to EL + 307.6 (ft).

An end of day reading was taken at Boring B and groundwater was observed at a depth of 27.9 ft, or EL +288.1 (ft). The boring sidewall cave-in was recorded at 28 ft, or at about EL + 288 (ft)

Groundwater level readings were measured in the PVC pipes at SB-01 and SB-09 between 24 hours and 72 hours after drilling was completed. The groundwater was observed at a depth of 13.5 ft or EL + 319.5 (ft) in boring SB-01, and at a depth of 15.3 ft or EL + 304.5 (ft) in boring SB-09.

All borings were backfilled after at least 24 hours of drilling using the drilling spoil. Borings drilled in asphalt areas were patched.

Groundwater in this geology typically lies a few feet above the disintegrated rock/bedrock surface. However, the presence of the terrace soils above the residual profile indicates that groundwater could be between EL +320 (ft) and EL +305 (ft). The higher readings may also be indicative of a perched groundwater condition.

The groundwater levels on the logs indicate our estimate of the hydrostatic water table at the time of our subsurface exploration. The final design should anticipate the fluctuation of the hydrostatic water table depending on variations in precipitation, surface runoff, pumping, evaporation, leaking utilities, and similar factors.

#### **5.4 In-Situ Infiltration Test Results**

To evaluate subgrades for infiltration feasibility at the site, our subcontractor drilled six soil test borings (designated as SWM-1 through SWM-6) at the site to a depth of 15 ft to 16 ft below existing grades. Following the completion of the approximate 24-hour groundwater level readings in these borings, an offset probe-hole was drilled adjacent to each of the borings to depths of about 6 ft below surface grades. A 5-inch diameter PVC pipe was placed in the offset probe-hole and about 24 inches of water was placed in the bottom of the pipe. Following the approximate 24-hour pre-soaking period, the infiltration testing was performed by personnel from our office by monitoring the drop in the water level at 1-hour intervals for a total of 4 hours. The infiltration rate at each boring location is determined as the average of the water drop observed over the 4-hour period.

The results of the in-situ infiltration testing is summarized in the table below. The testing depths were selected by the Civil Engineer.

**Table 5.1: Summary of In-Situ Infiltration Test Results**

Boring Number	Approximate Ground Surface Elevation (ft)	Approximate Infiltration Test Depth Below Surface (ft)	Approximate Infiltration Test Elevation (ft)	Soil Classification at Test Depth (per USCS)	Infiltration Test Rate (inch/hour)
SWM-1	EL +326.2	6.0	EL +320.2	clayey SAND with gravel (SC)	2.1
SWM-2	EL +326.4	6.0	EL +320.4	clayey SAND (SC)	1.2
SWM-3	EL +324.5	6.0	EL +318.5	clayey SAND with gravel (SC)	2.1
SWM-4	EL +315.8	6.0	EL +309.8	clayey SAND (SC)	0.14
SWM-5	EL + 315.0	6.0	EL +309.0	LEAN CLAY with sand (CL)	0.2
SWM-6	EL + 328.8	6.0	EL +322.8	clayey SAND (SC)	1.1

Per Appendix D.1 of the Maryland Department of the Environment (MDE) Stormwater Design Manual, an infiltration rate greater than 0.52 inch per hour is considered to be suitable. It should be noted, however, that the infiltration rates may vary at other locations at the site due to variable conditions of soils, compactness, gradation, etc. The design should account for such variations.

### 5.5 USDA Classification and Correlated Infiltration Rates

United States Department of Agriculture (USDA) classification testing was conducted on jar samples obtained from 5.0 ft to 7.0 ft at the SWM-2 and SWM-6 locations and from 6.0 ft to 8.0 ft at the SWM-1 and SWM-3 through SWM-5 locations. The lab testing results are included in **Appendix C** and summarized in the table below.

**Table 5.2: USDA Textural Classification and Minimum Infiltration Rates**

Boring Number	Sample Depth (ft)	USDA Textural Classification	Minimum Infiltration Rate Per Published Correlations (inches/hour)
SWM-1	6-8	SANDY LOAM	1.02
SWM-2	5-7	SANDY LOAM	1.02
SWM-3	6-8	SANDY LOAM	1.02
SWM-4	6-8	SANDY LOAM	1.02
SWM-5	6-8	SILT LOAM	0.27
SWM-6	5-7	LOAMY SAND	2.41

## **5.6 Seismic Site Classification**

We evaluated the Seismic Site Class for this project according to the 2015 International Building Code (IBC). Our analysis indicates Site Class D for this location. This Site Class was evaluated based on SPT values.



**6.0 SITE GRADING AND EARTHWORK**

In order to construct the new building, the existing Falcon Hall and Science South building will need to be demolished and their foundation systems removed in their entirety. All existing fill in the new building footprint will also need to be removed. Considering the existing building lowest levels of EL +307 (ft) to EL +302 (ft) for Falcon Hall and EL +326 (ft) for the Science South building, cuts of up to 15 ft and fills of up to 18 ft will be required to reach the new building’s lowest level at EL +320 (ft). Existing fill removal should extend at least 2 ft beyond the bottom edges of the exterior footings of the building. Benching of the excavations is also recommended to provide for level placement and compaction of the backfill.

Recommendations for preparation of subgrades to receive new compacted fill, compacted fill soil requirements, placement, and compaction criteria, as well as fill settlement are presented in subsequent sections.

**6.1 Preparation of Subgrades to Receive Compacted Fill**

Subgrades to receive compacted structural fill for building or pavement support should be stripped of vegetation, topsoil, organic matter, and the fill soils of Stratum A. Our subsurface exploration indicated topsoil to depths of up to 5 inches below the ground surface in some locations. This depth may vary at other locations.

At the building boring locations, the highest suitable subgrade elevations where new compacted fill can be placed are presented in the table below:

**Table 6.1: Estimated Elevation of Suitable Compacted Fill Subgrades**

<b>Boring Number</b>	<b>Estimated Elevation of Suitable Compacted Fill Subgrade (ft)</b>
SB-01	EL +329
SB-02	EL +328
SB-03	EL +322
SB-04	EL +324
SB-05/SWM-4	EL +311
SB-06	EL +323
SB-07	EL +326
SB-08	EL +315
SB-09	EL +314
SB-10	EL + 302
Boring A	EL + 323
Boring B	EL + 315

The Geotechnical Engineer should evaluate the suitability of the fill subgrades. The stripped subgrades should be proofrolled with a loaded dump truck to evaluate the subgrade suitability for support of the compacted structural fill prior to any undercutting or initiation of fill placement. Areas that exhibit excessive pumping, weaving, or rutting should be scarified, dried and recompacted, or undercut and

replaced with compacted structural fill as recommended by the Geotechnical Engineer. Subgrade evaluation techniques complementary to proofrolling could include a combination of probing with a penetrometer, drilling hand augers, or observing test pits.

When excavation of unsuitable materials is required, it should be performed in a manner to limit disturbance of the underlying suitable material. The excavation should be performed under the observation of the Geotechnical Engineer to evaluate the required excavation depths. Groundwater is expected to be encountered during fill placement and dewatering will be required during construction.

Compacted structural fill subgrades should be kept free of ponded water. If springs or other flowing water is present at the compacted structural fill subgrade level, the Contractor should direct water to discharge beyond the fill limits. Recommendations for discharging springs should be provided by the Geotechnical Engineer.

Compacted structural fill subgrades should be free of snow, ice, and frozen soils. If snow, ice, or frozen soils are present at subgrade levels, these materials should be removed as recommended by the Geotechnical Engineer.

The existing structures present on site will need to be removed before earthwork construction. Therefore, foundations and other associated debris will be encountered during grading activities and should be completely removed from the proposed building area. Existing foundations and walls in the proposed pavement areas should be removed to at least 2 ft below the design pavement subgrade level. Existing utilities and drainage structures within the building area should be removed and replaced with compacted structural fill.

Compacted structural fill subgrades should not be steeper than about 4H:1V. If steeper slopes are present, subgrades should be benched to permit placement of horizontal lifts of fill.

## **6.2 Compacted Fill**

Compacted structural fill and backfill in building and pavement areas should consist of material classifying as SM, SP, SW, GC, GM, GP or GW according to ASTM D2487. In addition, fill materials should exhibit Liquid Limit and Plasticity Index values of less than 40 and 15, respectively. Fill materials should not contain particles larger than 3 inches. On-site soils of Strata B2 and C2 are generally expected to meet these criteria. Part of the fill soils of Stratum A can be considered for re-use as compacted structural fill provided they are free of deleterious materials and meet the criteria above. Importation of fill should be anticipated.

Compacted structural fill should be placed in maximum 8-inch thick horizontal, loose lifts. Fill should be compacted to at least 95 percent of the maximum dry density per ASTM D698 (Standard Proctor), except that the top 12 inches in pavement areas should be compacted to at least 100 percent of the same standard. Soil moisture contents at the time of compaction should be within 3 percent of the soils' optimum moisture content.

Backfill placed in excavations, trenches, and other areas that large compaction equipment cannot access should be placed in maximum 6-inch thick lifts. Backfill should meet the material, placement, and compaction requirements outlined above.

Successful re-use of the excavated, on-site soils as compacted structural fill will depend on their natural moisture contents during excavation. Scarifying and drying of these soils should be anticipated to achieve the recommended compaction. Drying of these soils will likely result in some delays, and may not be possible during cooler, wetter weather. We recommend that the earthwork be performed during the warmer, drier times of the year.

### **6.3 Fill Settlement**

We anticipate as much as 18 ft of fill will be placed to reach the proposed lowest level of the building. The subgrade soils are expected to settle under the weight of the proposed fill and the new building. Construction of structures and pavement in fill areas should not begin until settlement has essentially ceased. Settlement plates should be installed on the subgrade within the new building footprint prior to placing the compacted structural fill. We anticipate that settlement will take about one to three months to dissipate. Please note that areas outside of the building footprint where new compacted structural fill is planned, specifically green areas where no significant loading (vehicular or structurally-related) is anticipated, will not require monitoring with settlement plates.

Settlement plates should consist of a 24 x 24 x ½ -inch steel plate with a 2-inch steel riser pipe welded to its center. The plate should be placed on the subgrade, and the elevation of the plate and top of the riser should be recorded before fill placement. As fill operations progress, the Contractor should extend the riser pipe to remain above the fill surface. The elevation of the top of the riser should be recorded immediately before and after attaching an extension. The elevation of the riser should be recorded daily. After completion of the fill, the elevation of the top of the riser should be recorded two times a week until settlement has essentially ceased. SEDC should review the settlement readings to confirm that settlement has dissipated, prior to foundation installation.

Settlement plate readings should be taken to the nearest 0.005 ft and referenced to a benchmark well beyond the influence of the fill placed. Precautions should be taken to prevent damaging the settlement plates during fill operations. The general Contractor should furnish all labor and materials, and perform all operations needed for installation and maintenance of the settlement plates.

Grading plans should be provided to SEDC for review to see if there are any changes to our recommendations.

## 7.0 FOUNDATION RECOMMENDATIONS

We based our geotechnical engineering analysis on the information developed from our subsurface investigation, along with the project development plans, site plans, and the structural loading furnished to our office. As noted in **Section 6.0**, present day Falcon Hall and the Science South building will be demolished and the building foundation systems removed in their entirety. New compacted structural fill will then be placed to reach the proposed building's lowest level at EL +320 (ft). The new building will have maximum column loads of about 200 kips to 300 kips and will have typical column spacing of about 30 ft by 30 ft.

Based on the above considerations, we recommend supporting the new building on spread footings founded on new compacted structural fill or medium dense and firm natural soils of Strata B1, B2, C1, and C2. The following sections of the report provide our detailed recommendations.

### 7.1 Spread Footings

We consider spread footings suitable for support of the proposed building. Footings should be founded on new compacted structural fill or suitable natural soils of Strata B1, B2, C1 and C2. We recommend footings supported on these materials be designed for a net allowable soil bearing pressure of 3,000 psf. These bearing pressures provide a factor of safety against general bearing capacity failure of at least 3.0.

The above allowable soil bearing pressures may be increased by 33 percent for wind and seismic loads when used in conjunction with load combinations defined in IBC Section 1605.3.2, Alternative Basic Load Combinations for use with allowable stress design. This increase is not applicable for other allowable stress load combinations, strength design or load and resistance factor design.

Suitable subgrade elevations where new compacted structural fill can be placed are detailed in **Section 6.1**. For planning purposes, the elevation of suitable materials between borings may be considered to vary linearly between boring locations.

All footing subgrades should be observed by the Geotechnical Engineer prior to placement of concrete to verify subgrade materials are as anticipated. If groundwater is encountered during footing excavation, dewatering will be required during construction. If unsuitable soils are encountered at the design bearing grade, these soils should be removed and replaced as recommended by the Geotechnical Engineer. Unsuitable soils should be replaced with new compacted fill, open graded crushed stone such as AASHTO No. 57, or lean concrete.

Settlements of shallow foundations supported on suitable natural soils are not expected to exceed about 1 inch. Differential settlements between similarly loaded footings are not expected to exceed about half this value.

Column and wall footings should be at least 24 and 16 inches wide, respectively, for shear considerations. Exterior footings should be founded at least 2.5 ft below final exterior grades for frost protection. Interior footings may be founded at nominal depths below the floor slabs. Where bearing grades between adjacent footings vary, the slope between the bottom edges of adjacent footings should not be steeper than 1.5H:1V. When available, SEDC should be allowed to review the design foundation drawings.

## **8.0 FLOOR SLAB RECOMMENDATIONS**

The proposed floor slabs should be supported on suitable natural soils of Strata B1, B2, C1, and C2 or compacted structural fill. A modulus of subgrade reaction,  $k$ , of 100 kcf should be used in the design of floor slabs. The recommended modulus value is for a 1-ft-square plate. Some slab design software may consider different definitions of  $k$  for input. The Structural Engineer should contact our office if their software considers a different definition of  $k$ .

A 4-inch crushed stone or washed gravel capillary moisture barrier should underlie floor slabs on grade. Moisture barrier material should consist of AASHTO No. 57 crushed stone. The Contractor should compact the stone in place with at least two passes of suitable vibratory compaction equipment. A 10-mil polyethylene liner should be installed over the crushed stone layer as a vapor barrier and to prevent concrete intrusion into the stone. Floor-slab subgrades should be observed and approved by the Geotechnical Engineer prior to placing the washed gravel or crushed stone base.

The Contractor should compact floor slab subgrades before placing moisture barrier materials to repair any disturbance that may occur due to construction operations. Since floors will be slab-on-grade, utility excavations should be backfilled with compacted structural fill as defined in this report.

## 9.0 RETAINING STRUCTURE RECOMMENDATIONS

The proposed structure includes basement walls. Recommendations for the design of these walls are presented in the following sections. If loading docks or retaining walls are planned, these locations should be made known to us and recommendations can be provided.

### 9.1 Below-Grade Walls

The building below-grade walls must be designed to resist lateral earth pressures developed from the surrounding soil, backfill, and surcharge loads. We recommend an average fluid pressure of  $50H$  (psf), where  $H$  is the height of the wall in feet, for the design of below-grade walls to account for soil pressures. The recommended equivalent fluid pressure assumes a horizontal backfill. The horizontal pressure from surcharges, if applicable, will be 0.42 times the vertical surcharge using a uniform pressure distribution in addition to the equivalent fluid pressure provided above.

A diagram illustrating the design of earth pressure recommendations on below-grade walls is included as **Figure 3**. The pressures shown are expected to develop from surrounding soils and/or backfill retained by below-grade walls. Hydrostatic pressures are not included in the recommended lateral earth pressure, as foundation drains should be installed as discussed below. Any surcharge adjacent to the walls should be considered in the evaluation of lateral earth pressure as shown on the diagram. Any backfill placed along the back of the walls should meet the compaction requirements for backfill against below-grade or site retaining walls as detailed below.

### 9.2 Backfill for Below-Grade Walls

Backfill materials for walls should consist of material classifying as SM or more granular according to ASTM D2487. In addition, fill materials should exhibit Liquid Limit and Plasticity Index values of less than 40 and 15, respectively. This classification includes open-graded crushed stone such as AASHTO No. 57 crushed stone. Free-draining backfill should be placed in the zone extending from the base of the wall upwards at 45 degrees.

The Contractor should place backfill in maximum 8-inch thick loose lifts and compact each lift to at least 95 percent of maximum dry density according to ASTM D698 (Standard Proctor). The Contractor should place crushed stone backfill in maximum 12-inch thick lifts, and compact each lift using suitable vibratory equipment. Only light hand-operated equipment should be used to compact backfill against walls. The Structural Engineer of Record should approve the size of the compaction equipment.

## 10.0 SUBDRAINAGE RECOMMENDATIONS

Subdrainage below the floor slab and behind below-grade walls will be required. Dewatering during construction will also be required as discussed in **Section 11.3**.

### 10.1 Subdrainage for Below-Grade Walls

Earth pressure recommendations provided in this report do not include hydrostatic pressure since subdrainage will be provided behind the basement walls. If the excavation is sloped, subdrainage should consist of perimeter subdrains located on top of the wall footing, next to the wall. Subdrains should consist of 4-inch slotted, corrugated polyethylene tubing according to ASTM F405, surrounded by at least 4 inches of filter drainage material. A drainage geotextile should wrap around the drainage material. Subdrains should drain by gravity to an outlet, sump, or storm sewer.

For sloped and sheeting and shoring excavations, geocomposite drainage panels consisting of Miradrain G100N or equivalent should be installed continuously on all basement walls. Drainage panels should be placed along the entire wall face to within 1.5 ft of the finished grade. The Contractor should bind the edges of the panels with drainage geotextile to limit the potential for soil intrusion into the drainage system.

Wall subdrainage may be provided using weepholes. Weepholes should be 3 inches in diameter and should be installed on 8-ft centers. A filter plug consisting of at least one cubic foot of drainage filter material wrapped in drainage geotextile should be placed behind each weephole.

Drainage filter material should consist of AASHTO No. 78 aggregate. Drainage geotextile should consist of a non-woven geotextile such as Mirafi 140N, or equivalent fabric.

### 10.2 Basement Subdrainage

Based on the groundwater level readings taken during the subsurface investigation, groundwater is anticipated to be at about the same elevation of the proposed lowest level. Therefore, we recommend installing a permanent subdrainage system to maintain groundwater levels below the lowest level floor slab elevations. In addition to the perimeter subdrains for the walls discussed above, the subdrainage system should include an underfloor drainage blanket and a series of interior underslab subdrains. Recommended subdrainage system details are shown on **Figure 4**.

The drainage blanket should consist of a 4-inch thick layer of drainage filter material placed beneath the floor slab. Since this layer is part of the subdrainage system, the drainage filter material should be protected from the inclusion of non-filter materials.

Interior underslab subdrains should be constructed on a maximum spacing of 40-ft centers and connected to headers at both ends of the subdrain. Subdrains should consist of 4-inch diameter, corrugated, slotted, polyethylene pipe according to ASTM F405. Slot widths should not exceed  $\frac{1}{8}$  inch. Drainage pipes should be surrounded by at least 4 inches of drainage filter material on sides and bottom and 2 inches of drainage filter material on top. The drainage filter material should be wrapped with non-woven drainage geotextile. Pipe inverts should be set at least 10 inches below the bottom of the floor slab.

The subdrainage system should drain by gravity to a sump pit installed in the lowest level, where drainage can be discharged by pumping. For preliminary design, we recommend a pump capacity of about 30 gallons per minute be considered. We recommend that the pump be located in areas closest to the deepest excavation of the building. The final pump should be sized based on the results of field measurements during construction. A redundant pump system should be provided. Also, a backup power supply or non-electrical backup pump should be incorporated into the system.

Elevator pits and other portions of the structure that extend below the subdrainage system should be water-proofed and designed to resist full hydrostatic pressure. In occupied spaces, installation of both waterproofing and subdrainage will provide the best coverage.

The design and construction of a subdrainage system is not foolproof. System failures may occur due to various causes. Periodic maintenance, including flushing, and possible chemical treatment to flush out soil particles and remove mineral or bacterial deposits that may restrict flow in the pipes will be required. Adequate cleanouts should be included in the subdrainage system design to permit access to the entire system. Generally, cleanouts will also be located at upstream ends of laterals and at critical intersections. The subdrain system should be laid out to provide redundant flow paths where possible.

Subdrainage requirements have been prepared to assist in the design of a subdrainage system for this project. These recommendations are based on the subsurface and groundwater data reviewed herein. If substantially different groundwater flow quantities are encountered during construction or if the lowest floor levels are changed, we should be contacted so that we may evaluate effects on the recommendations given herein. Construction plans should depict the entire subdrainage system, including sump pumps and cleanout locations and the layout of interior collection or trunk lines. Our office can prepare subdrainage system design drawings upon request.



## **11.0 CONSTRUCTION CONSIDERATIONS**

### **11.1 Site Grading and Earthwork**

The test boring data indicate the approximate depth of topsoil and fill based on our visual identification procedures. Drying and reworking of the soils are likely to be difficult during periods of wet months. We recommend that the earthwork phases of this project be performed during the warmer, drier times of the year to limit the potential for disturbance of on-site soils.

Traffic on stripped or undercut subgrades should be limited to reduce disturbance of underlying soils. Also, using lightweight, track-mounted dozer equipment for stripping will limit the disturbance of underlying soils, and may reduce the undercut volume needed. The Contractor should provide site drainage to maintain subgrades free of water and to avoid saturation and disturbance of the subgrade soils before placing compacted structural fill, pavement base course or moisture barrier material. This will be important during all phases of the construction work. The Contractor should be responsible for reworking of subgrades and compacted structural fill that were initially considered suitable but were later disturbed by equipment and/or weather.

### **11.2 Foundations**

#### **11.2.1 Spread Footings**

The Contractor should exercise care during excavation for spread footings so that as little disturbance as possible occurs at the foundation level. The Contractor should carefully clean loose or soft soils from the bottom of the excavation before placing concrete. A Geotechnical Engineer from our firm should observe actual footing subgrades during construction to evaluate whether subgrade soils meet the requirements as recommended in this report.

Footing subgrades needing undercut may be concreted at the elevation of undercut or backfilled to the original design subgrade elevation with new compacted structural fill, an open-graded crushed stone such as AASHTO No. 57 stone, or lean concrete. Concreting should take place the same day as the excavation of footings.

### **11.3 Construction Dewatering**

The site geology consists of relatively low-permeability lenses and layers of finer grained soil zones separated by higher permeability lenses and layers of granular materials. Most site groundwater flow will come from saturated higher permeability layers and so-called "perched water zones" where groundwater rests on or in higher elevation lower-permeability materials. In addition, nodules, layers, and lenses of iron oxide cemented soils may be present that can have a weak rock-like consistency. The iron oxide zones may be in well-defined layers or may be erratically present both vertically and horizontally through the soil profile. These layers can act to perch water. Deeper permeable zones may also be present that have higher water pressure than the overlying saturated materials, which can result in "artesian" water conditions. This could cause soils in the excavation to soften and lose strength if not properly dewatered.

A deep-well dewatering system is typically used to dewater these sites. Dewatering by deep-wells will typically not fully dewater the site. Trenching and sumping from inside the excavation to collect perched water and site runoff is required in virtually all excavations and may be extensive depending on the amount of perched water. In some locations, deep-wells and trenching and sumping cannot sufficiently dewater all areas and well points may be required to lower the groundwater to allow site construction to progress. Precipitation and seasonal variation in groundwater levels will also impact the amount and depth of groundwater encountered and the extent and amount of dewatering and water control measures that must be taken.

Lower-permeability zones that can produce perched water conditions may not be readily evident from the boring logs. This is because thin, lower permeability layers may not be disclosed by the industry standard drilling and sampling processes that sample on 5-ft vertical intervals.

Dewatering at the site should be completed by a competent dewatering contractor with at least 5 years of experience in the region. Groundwater levels should be maintained at least 4 ft below the lowest excavation levels. Sufficient time must be allowed in the construction schedule for the dewatering contractor to install wells, begin well operation and pump wells to lower groundwater levels to the required elevation.

#### **11.4 Subdrainage**

The Contractor should exercise care when placing and backfilling subdrainage pipe to avoid damage to the subdrainage system during installation.

#### **11.5 Engineering Services During Construction**

The engineering recommendations provided in this report are based on the information obtained from the subsurface exploration and laboratory testing. However, conditions on the site may vary between the discrete locations observed at the time of our subsurface exploration. The nature and extent of variations between borings may not become evident until during construction.

To account for this variability, we should provide professional observation and testing of subsurface conditions revealed during construction as an extension of our engineering services. These services will also help in evaluating the Contractor's conformance with the plans and specifications. Because of our unique position to understand the intent of the geotechnical engineering recommendations, retaining Schnabel for these services will allow us to provide consistent service throughout the project construction.

## 12.0 GENERAL SPECIFICATION RECOMMENDATIONS

An allowance should be established to account for possible additional costs that may be required to construct earthwork and foundations, as recommended in this report. Additional costs may be incurred for a variety of reasons including variation of soil and rock conditions between borings, wet on-site soils, groundwater, etc. The project specifications should indicate the contractor's responsibility for providing adequate site drainage during construction. Inadequate drainage could lead to disturbance of soils by construction traffic, which could result in the need to undercut disturbed soils.

This report may be made available to prospective bidders for informational purposes. We recommend that the project specifications contain the following statement:

*Schnabel Engineering DC, Inc. has prepared this geotechnical engineering report for this project. This report is for informational purposes only and is not part of the contract documents. The opinions expressed represent the Geotechnical Engineer's interpretation of the subsurface conditions, tests, and the results of analyses conducted. Should the data contained in this report not be adequate for the Contractor's purposes, the Contractor may make, before bidding, independent exploration, tests, and analyses. This report may be examined by bidders at the office of the Owner, or copies may be obtained from the Owner at nominal charge.*

The contract documents should include the boring data provided in **Appendix A**.

Additional data and reports prepared by others that could have an impact upon the contractor's bid should also be made available to prospective bidders for informational purposes.

### **13.0 LIMITATIONS**

We based the analyses and recommendations submitted in this report on the information revealed by our exploration. We attempted to provide for normal contingencies, but the possibility remains that unexpected conditions may be encountered during construction.

This report has been prepared to aid in the evaluation of this site and to assist in the design of the project. It is intended for use concerning this specific project. We based our recommendations on information on the site and proposed construction as described in this report. Substantial changes in loads, locations, or grades should be brought to our attention so we can modify our recommendations as needed. We would appreciate an opportunity to review the plans and specifications as they pertain to the recommendations contained in this report, and to submit our comments to you based on this review.

We have endeavored to complete the services identified herein in a manner consistent with that level of care and skill ordinarily exercised by members of the profession currently practicing in the same locality and under similar conditions as this project. No other representation, express or implied, is included or intended, and no warranty or guarantee is included or intended in this report, or other instrument of service.

# FIGURES

Figure 1: Site Vicinity Map

Figure 2: Approximate Boring Location Plan

Figure 3: Lateral Earth Pressure Diagram for Design of Below-Grade Walls

Figure 4: Subdrainage Detail





Esri, HERE, Garmin, © OpenStreetMap contributors  
 Sources: Esri, HERE, Garmin, USGS, Intermap, INCREMENT P, NRCan, Esri Japan, METI, Esri  
 China (Hong Kong), Esri Korea, Esri (Thailand), NGCC, © OpenStreetMap contributors, and the  
 GIS User Community

NOT TO SCALE



THE CATHERINE AND ISIAH LEGGETT BUILDING  
 MONTGOMERY COLLEGE  
 TAKOMA PARK, MARYLAND  
 18C41041

SITE VICINITY  
 MAP

FIGURE 1



**LEGEND**

 APPROXIMATE SEDC BORING LOCATION

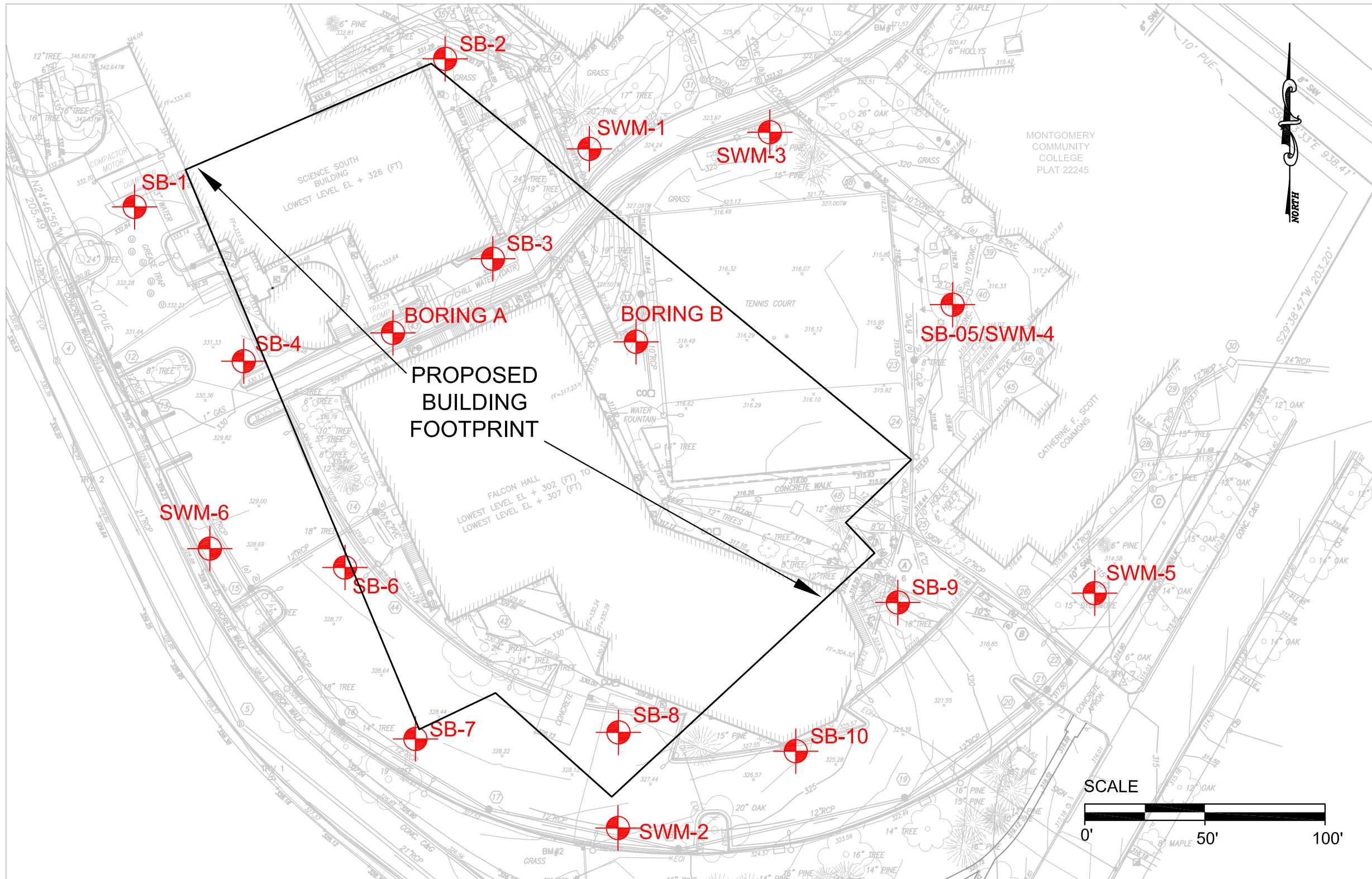

BASE PLAN PROVIDED BY A. MORTON THOMAS AND ASSOCIATES, INC.

	THE CATHERINE AND ISIAH LEGGETT BUILDING MONTGOMERY COLLEGE TAKOMA PARK, MARYLAND	APPROXIMATE BORING LOCATION PLAN	DRAWN BY: M. KHACHAN	APPROXIMATE SCALE: AS SHOWN
		PROJECT NO. 18C41041 FIGURE 2	REVIEWED BY: J. BENTEL	DATE: MAY 2019

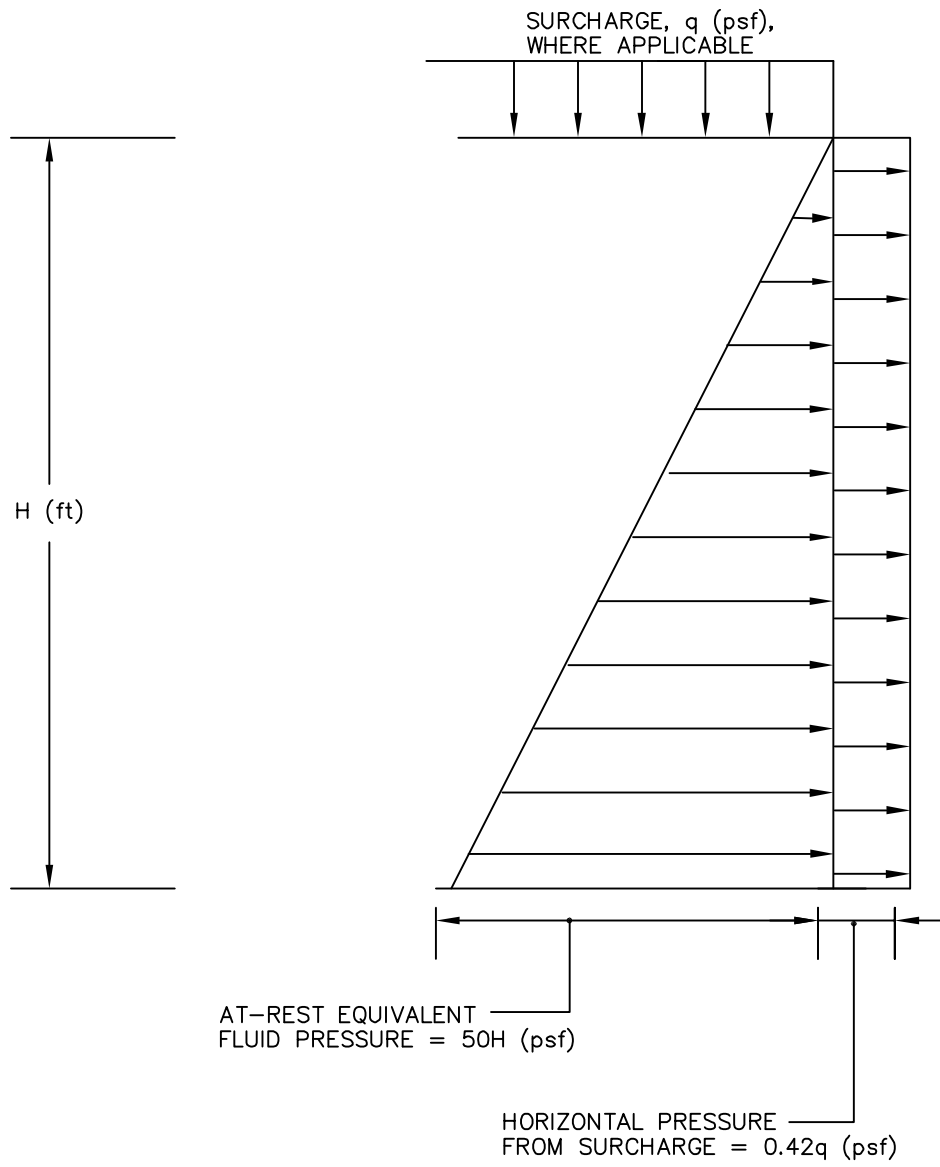

NOTES:

- 1) EARTH PRESSURE DIAGRAM SHOWN ASSUMES FULL DRAINAGE OF HYDROSTATIC PRESSURE AS A SUBDRAINAGE SYSTEM SHOULD BE UTILIZED.



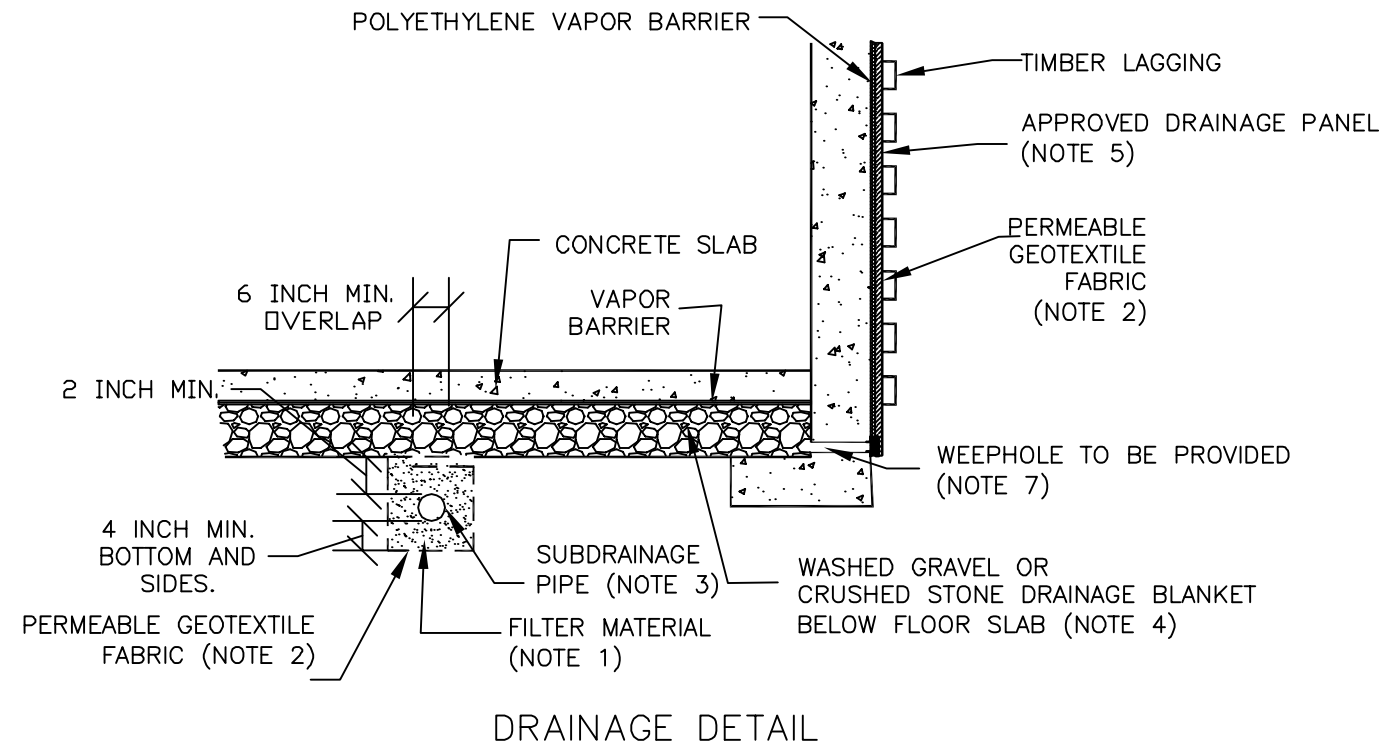

DRAINAGE DETAIL

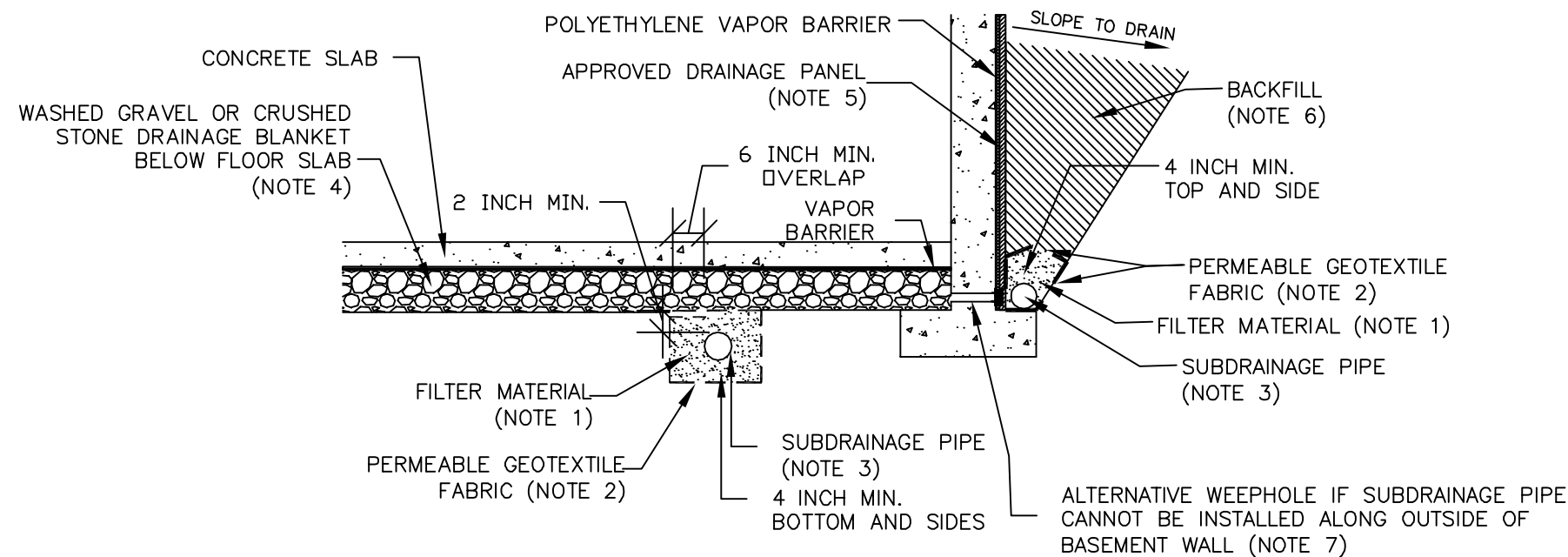

ALTERNATIVE DRAINAGE DETAIL FOR SLOPED EXCAVATION

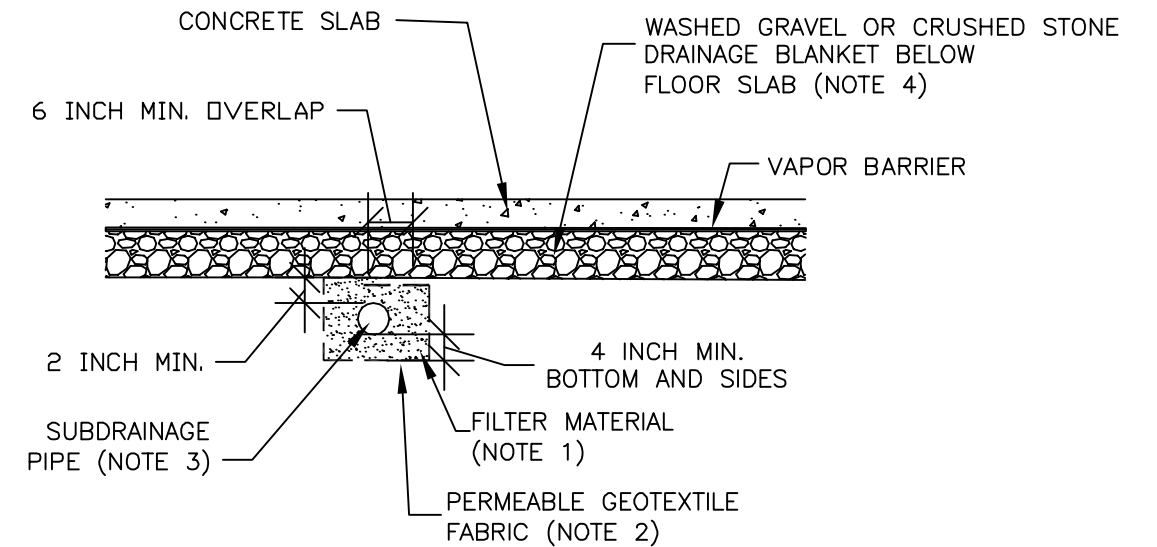

INTERIOR FLOOR SLAB DRAINAGE DETAIL

FOUNDATION DRAIN NOTES

1. FILTER MATERIAL GRADATION SHOULD SATISFY REQUIREMENTS FOR AASHTO NO.78 COARSE AGGREGATE.
2. PERMEABLE FABRIC SHOULD HAVE EQUIVALENT OPENING SIZE NOT LARGER THAN THE NO. 70 U.S. STANDARD SIEVE SIZE.
3. SUBDRAINAGE PIPING SHOULD BE 4 INCH DIAMETER SLOTTED CORRUGATED POLYETHYLENE (P.E. TUBING) ACCORDING TO ASTM F-405 WITH MAXIMUM 1/8 INCH SLOT WIDTH FOR AT LEAST THE LOWER 120° SECTOR. PIPING SHOULD BE INSTALLED TO OUTLET INTO A STORM SEWER OR SUMP WITH A PUMP.
4. WASHED GRAVEL OR CRUSHED STONE DRAINAGE BLANKET SHOULD SATISFY GRADATION REQUIREMENTS FOR AASHTO NO.57 STONE AND BE AT LEAST 4 INCHES THICK.
5. APPROVED DRAINAGE PANEL SHOULD SATISFY MINIMUM THICKNESS OR FLOW CAPACITY REQUIREMENTS AS DETERMINED BY THE GEOTECHNICAL ENGINEER. GEOTEXTILE FILTER CLOTH SHOULD BE PLACED SUCH THAT IT IS IN CONTACT WITH THE SOIL BACKFILL OR EXCAVATION SHEETING.
6. BACKFILL MATERIAL TO MEET REQUIREMENTS IN PROJECT SPECIFICATIONS.
7. WEEPHOLES WHEN USED TO BE PROVIDED AT MAXIMUM SPACING OF 8 FEET ON CENTER ALONG BASE OF WALL. WEEPHOLES SHALL CONSIST OF 3 INCH I.D. SOLID POLYETHYLENE PIPE.
8. DRAINREAT™ SHALL BE USED FOR CONNECTION BETWEEN WEEPHOLE AND DRAINAGE BOARD AS SHOWN ON DETAIL. INSTALLATION TO BE DONE IN ACCORDANCE WITH MANUFACTURERS RECOMENDATIONS.



THE CATHERINE AND ISIAH LEGGETT  
BUILDING  
MONTGOMERY COLLEGE  
TAKOMA PARK, MARYLAND

DRAWN BY: M. KHACHAN	FIGURE NUMBER: 4	SUBDRAINAGE DETAILS
REVIEWED BY: B. KHOURI	DATE: DECEMBER 2018	

# **APPENDIX A**

## **SUBSURFACE EXPLORATION DATA**

Subsurface Exploration Procedures (1 sheet)  
General Notes for Subsurface Exploration Logs (1 sheet)  
Identification of Soil (1 sheet)  
Boring Logs, SB-01 through SB-10, SWM-1 through SWM-6, Boring A, and Boring B (30 sheets)

# SUBSURFACE EXPLORATION PROCEDURES

## Test Borings – Hollow Stem Augers

The borings are advanced by turning an auger with a center opening of 2¼ or 3¼ inches. A plug device blocks off the center opening while augers are advanced. Cuttings are brought to the surface by the auger flights. Sampling is performed through the center opening in the hollow stem auger by standard methods after removal of the plug. Usually, no water is introduced into the boring using this procedure.

## Standard Penetration Test Results

The Standard Penetration Test (SPT) is performed in the borings at regular depth intervals to collect soil samples. The numbers in the Sampling Data column of the boring logs represent SPT results. Each number represents the blows needed to drive a 2-inch O.D., 1⅝-inch I.D. split-spoon sampler 6 inches, using a 140-pound hammer falling 30 inches. The sampler is typically driven a total of 18 or 24 inches. The first 6 inches are considered a seating interval. The total of the number of blows for the second and third 6-inch intervals is the SPT “N value.” The Standard Penetration Test is performed according to ASTM D1586.

## Soil Classification Criteria

The group symbols on the logs represent the Unified Soil Classification System Group Symbols (ASTM D2487) based on visual observation and limited laboratory testing of the samples. Criteria for visual identification of soil samples are included in this appendix. Some variation can be expected between samples visually classified and samples classified in the laboratory.

## Temporary PVC Pipe

Temporary PVC pipe was installed in boring SB-01 and SB-09 by inserting a hand-slotted, 1¼-inch PVC pipe in each of these borings. After obtaining 24-hour groundwater level readings, these pipes were removed and the boreholes were backfilled with soil spoils.

## Boring Locations and Elevations

Boring locations were staked by A. Morton Thomas and Associates (AMT). Coordinates and elevations were provided to us by AMT. Approximate boring locations are shown on **Figure 2**. Ground surface elevations are indicated on the boring logs. Locations and elevations should be considered no more accurate than the methods used to determine them.

# GENERAL NOTES FOR SUBSURFACE EXPLORATION LOGS

1. Numbers in sampling data column next to Standard Penetration Test (SPT) symbols indicate blows required to drive a 2-inch O.D., 1½-inch I.D. sampling spoon 6 inches using a 140-pound hammer falling 30 inches. The Standard Penetration Test (SPT) N value is the number of blows required to drive the sampler 12 inches, after a 6-inch seating interval. The Standard Penetration Test is performed in general accordance with ASTM D1586.
2. Visual classification of soil is in accordance with terminology set forth in "Identification of Soil." The ASTM D2487 group symbols (e.g., CL) shown in the classification column are based on visual observations.
3. Estimated water levels indicated on the logs are only estimates from available data and may vary with precipitation, porosity of the soil, site topography, and other factors.
4. Refusal at the surface of rock, boulder, or other obstruction is defined as an SPT resistance of 50 blows for 1 inch or less of penetration.
5. The logs and related information depict subsurface conditions only at the specific locations and at the particular time when drilled or excavated. Soil conditions at other locations may differ from conditions occurring at these locations. Also, the passage of time may result in a change in the subsurface soil and water level conditions at the subsurface exploration location.
6. The stratification lines represent the approximate boundary between soil and rock types as obtained from the subsurface exploration. Some variation may also be expected vertically between samples taken. The soil profile, water level observations and penetration resistances presented on these logs have been made with reasonable care and accuracy and must be considered only an approximate representation of subsurface conditions to be encountered at the particular location.
7. Key to symbols and abbreviations:



S-1, SPT  
5+10+1

Sample No., Standard Penetration Test  
Number of blows in each 6-inch increment

LL	Liquid Limit
MC	Moisture Content (percent)
PL	Plastic Limit
%Passing#200	Percent by weight passing a No. 200 Sieve

# IDENTIFICATION OF SOIL

## I. DEFINITION OF SOIL GROUP NAMES (ASTM D2487)

## SYMBOL GROUP NAME

Coarse-Grained Soils More than 50% retained on No. 200 sieve	Gravels – More than 50% of coarse fraction retained on No. 4 sieve Coarse, ¾" to 3" Fine, No. 4 to ¾"	Clean Gravels Less than 5% fines	GW	WELL GRADED GRAVEL
			GP	POORLY GRADED GRAVEL
		Gravels with fines More than 12% fines	GM	SILTY GRAVEL
	Sands – 50% or more of coarse Fraction passes No. 4 sieve Coarse, No. 10 to No. 4 Medium, No. 40 to No. 10 Fine, No. 200 to No. 40	Clean Sands Less than 5% fines	SW	WELL GRADED SAND
			SP	POORLY GRADED SAND
		Sands with fines More than 12% fines	SM	SILTY SAND
SC			CLAYEY SAND	
Fine-Grained Soils 50% or more passes the No. 200 sieve	Silts and Clays – Liquid Limit less than 50 Low to medium plasticity	Inorganic	CL	LEAN CLAY
			ML	SILT
		Organic	OL	ORGANIC CLAY
				ORGANIC SILT
	Silts and Clays – Liquid Limit 50 or more Medium to high plasticity	Inorganic	CH	FAT CLAY
			MH	ELASTIC SILT
		Organic	OH	ORGANIC CLAY
				ORGANIC SILT
Highly Organic Soils	Primarily organic matter, dark in color and organic odor	PT	PEAT	

## II. DEFINITION OF SOIL COMPONENT PROPORTIONS (ASTM D2487)

			Examples
Adjective Form	GRAVELLY SANDY	>30% to <50% coarse-grained component in a fine-grained soil	GRAVELLY LEAN CLAY
	CLAYEY SILTY	>12% to <50% fine grained component in a coarse-grained soil	SILTY SAND
"With"	WITH GRAVEL WITH SAND	>15% to <30% coarse-grained component in a fine-grained soil	FAT CLAY WITH GRAVEL
	WITH GRAVEL WITH SAND	>15% to <50% coarse-grained component in a coarse-grained soil	POORLY GRADED GRAVEL WITH SAND
	WITH SILT WITH CLAY	>5% to <12% fine grained component in a coarse-grained soil	POORLY GRADED SAND WITH SILT

## III. GLOSSARY OF MISCELLANEOUS TERMS

<b>SYMBOLS</b> .....	Unified Soil Classification Symbols are shown above as group symbols. A dual symbol "-“ indicates the soil belongs to two groups. A borderline symbol "/" indicates the soil belongs to two possible groups.
<b>FILL</b> .....	Man-made deposit containing soil, rock and often foreign matter.
<b>PROBABLE FILL</b> .....	Soils which contain no visually detected foreign matter but which are suspect with regard to origin.
<b>DISINTEGRATED ROCK (DR)</b> .....	Residual materials with a standard penetration resistance (SPT) between 60 blows per foot and refusal. Refusal is defined as an SPT of 100 blows for 2" or less penetration.
<b>PARTIALLY WEATHERED ROCK (PWR)</b> .....	Residual materials with a standard penetration resistance (SPT) between 100 blows per foot and refusal. Refusal is defined as an SPT of 100 blows for 2" or less penetration.
<b>BOULDERS &amp; COBBLES</b> .....	Boulders are considered rounded pieces of rock larger than 12 inches, while cobbles range from 3 to 12-inch size.
<b>LENSES</b> .....	0 to ½-inch seam within a material in a test pit.
<b>LAYERS</b> .....	½ to 12-inch seam within a material in a test pit.
<b>POCKET</b> .....	Discontinuous body within a material in a test pit.
<b>MOISTURE CONDITIONS</b> .....	Wet, moist or dry to indicate visual appearance of specimen.
<b>COLOR</b> .....	Overall color, with modifiers such as light to dark or variation in coloration.

**Contractor:** Recon Drilling  
Leesburg, Virginia  
**Contractor Foreman:** U. Rodas  
**Schnabel Representative:** M. Khachan  
**Equipment:** CME-45B (Truck)  
**Method:** 2-1/4" I.D. Hollow Stem Auger  
**Hammer Type:** Auto Hammer (140 lb)  
**Dates Started:** 8/9/18 **Finished:** 8/10/18  
**Location:** See Location Plan  
**Ground Surface Elevation:** 333± (ft) **Total Depth:** 43.9 ft

Groundwater Observations						
	Date	Time	Depth	Casing	Caved	
Encountered	8/9	---	18.0'	---	---	
Completion	8/10	---	Dry	---	---	
Casing Pulled	8/10	---	13.3'	---	PIPE	
After Drilling	8/13	---	13.5'	---	PIPE	

TEST BORING LOG 18C41041 GINT LOGS.GPJ SCHNABEL DATA TEMPLATE 2008\_07\_06.GDT 5/21/19

DEPTH (ft)	MATERIAL DESCRIPTION	SYMBOL	ELEV (ft)	STRATUM	SAMPLING		TESTS	REMARKS
					DEPTH	DATA		
0.5	Asphalt; 6 inches		332.5					
1.0	GRAVEL BASE; 6 inches		332.0					
	PROBABLE FILL, sampled as sandy lean clay; moist, yellowish red, contains gravel, contains roots	FILL		A		S-1, SS 5+5+7 REC=18", 100%		
3.5	SANDY LEAN CLAY; moist, yellowish red, yellowish brown, and red, estimated 5-10% gravel	CL	329.5		5	S-2, SS 3+4+5 REC=18", 100%	PP = 3.50 tsf	
6.0	LEAN CLAY WITH SAND; moist, yellowish brown, gray, and red	CL	327.0	B1		S-3, SS 3+4+7 REC=18", 100%	LL = 39 PL = 24 MC = 19.0% % Passing #200 = 83.2 PP = 1.50 tsf	
8.5	POORLY GRADED SAND WITH CLAY AND GRAVEL; moist, yellowish red and white	SP-SC	324.5		10	S-4, SS 6+6+11 REC=18", 100%		
13.5	CLAYEY GRAVEL WITH SAND; moist, yellowish brown and white	GC	319.5	B2	15	S-5, SS 12+13+14 REC=18", 100%		
18.5	SILTY SAND; moist, light yellowish brown and gray, estimated 30-45% mica	SM	314.5		20	S-6, SS 23+10+8 REC=18", 100%		
23.5	SANDY SILT; moist, light yellowish red and gray, estimated 30 - 45% mica, estimated <5% rock fragments	ML	309.5	C2		S-7, SS 8+8+8 REC=18", 100%		

(continued)



**Schnabel Engineering DC**  
**TEST BORING LOG**

**Project:** The Catherine and Isiah Leggett Building  
 Montgomery College  
 7600 Takoma Ave, Takoma Park, Maryland

**Boring Number:** **SB-01**  
**Contract Number:** 18C41041  
**Sheet:** 2 of 2

DEPTH (ft)	MATERIAL DESCRIPTION	SYMBOL	ELEV (ft)	STRATUM	SAMPLING DATA		TESTS	REMARKS
					DEPTH	DATA		
	Change: gray, streaks of black	ML		C2	30	S-8, SS 5+7+10 REC=18", 100%		
33.5	DISINTEGRATED ROCK, sampled as sandy silt; moist, gray and black, streaks of yellowish brown, estimated 15-25% mica		299.5		35	S-9, SS 16+35+38 REC=18", 100%		
	Change: streaks of tan and yellowish red, estimated < 5% mica	DR		D	40	S-10, SS 37+50/5" REC=11", 100%		
43.9	Change: estimated 30 - 45% mica Bottom of Boring at 43.9 ft.		289.1			S-11, SS 50/5" REC=5", 100%		

TEST BORING LOG 18C41041 GINT LOGS.GPJ SCHNABEL DATA TEMPLATE 2008\_07\_06.GDT 5/21/19

**Contractor:** Recon Drilling  
 Leesburg, Virginia  
**Contractor Foreman:** W. Rodas  
**Schnabel Representative:** M. Khachan  
**Equipment:** CME 550 ATV  
**Method:** 2-1/4" I.D. Hollow Stem Auger  
  
**Hammer Type:** Auto Hammer (140 lb)  
**Dates Started:** 8/13/18 **Finished:** 8/14/18  
**Location:** See Location Plan  
  
**Ground Surface Elevation:** 331± (ft) **Total Depth:** 38.5 ft

Groundwater Observations					
	Date	Time	Depth	Casing	Caved
Encountered $\nabla$	8/14	---	17.0'	---	---
Completion	8/14	---	Dry	---	---
Casing Pulled	8/14	---	Dry	---	12.5'
End of Day	8/14	---	Dry	---	12.5'

TEST BORING LOG 18C41041 GINT LOGS.GPJ SCHNABEL DATA TEMPLATE 2008\_07\_06.GDT 5/21/19

DEPTH (ft)	MATERIAL DESCRIPTION	SYMBOL	ELEV (ft)	STRATUM	SAMPLING		TESTS	REMARKS
					DEPTH	DATA		
0.3	Topsoil; 3 inches PROBABLE FILL, sampled as sandy silt; moist, light brown, contains roots	FILL	330.9	A		S-1, SS 9+7+5 REC=16", 89%		
2.5	CLAYEY GRAVEL; moist, yellowish red, white, and brown	GC	328.6			S-2, SS 11+20+23 REC=18", 100%		
5.0	CLAYEY SAND WITH GRAVEL; moist, yellowish red and white	SC	326.1	5		S-3, SS 6+8+14 REC=18", 100%		
8.5	CLAYEY GRAVEL WITH SAND; moist, reddish brown  Change: mottles of yellowish brown	GC	322.6	B2	10	S-4, SS 11+16+12 REC=18", 100%		
					15	S-5, SS 11+14+16 REC=18", 100%		
18.5	POORLY GRADED GRAVEL; moist, white	GP	312.6		20	S-6, SS 15+11+9 REC=1", 6%		Poor Recovery
23.5	SANDY LEAN CLAY; wet, yellowish brown and gray, estimated 10-15% mica	CL	307.6	C1		S-7, SS 19+26+30 REC=2", 11%	PP =NA tsf	

(continued)





**Schnabel Engineering DC**  
**TEST BORING LOG**

**Project:** The Catherine and Isiah Leggett Building  
 Montgomery College  
 7600 Takoma Ave, Takoma Park, Maryland

**Boring Number:** **SB-02**  
**Contract Number:** 18C41041  
**Sheet:** 2 of 2

DEPTH (ft)	MATERIAL DESCRIPTION	SYMBOL	ELEV (ft)	STRATUM	SAMPLING DATA		TESTS	REMARKS
					DEPTH	DATA		
28.5	SANDY SILT; moist, yellowish red, brown and black, estimated 30-45% mica	CL	302.6	C1	30	S-8, SS 20+20+20 REC=2", 11%		Possible Boulder or Rock Ledge at 27 ft
33.5	DISINTEGRATED ROCK, sampled as sandy silt with gravel; moist, black, gray, olive and white, estimated 50-100% rock fragments, estimated 5-10% mica	ML	297.6	C2	35	S-9, SS 50/2" REC=1", 50%		
38.5		DR	292.6	D		S-10, SS 50/0.5" REC=0.5", 100%		
Bottom of Boring at 38.5 ft.								

**Contractor:** Recon Drilling  
 Leesburg, Virginia  
**Contractor Foreman:** U. Rodas  
**Schnabel Representative:** M. Khachan  
**Equipment:** CME-45B (Truck)  
**Method:** 2-1/4" I.D. Hollow Stem Auger  
  
**Hammer Type:** Auto Hammer (140 lb)  
**Dates Started:** 8/10/18 **Finished:** 8/10/18  
**Location:** See Location Plan

Groundwater Observations						
	Date	Time	Depth	Casing	Caved	
Encountered	8/10	---	21.0'	---	---	▽
Completion	8/10	---	16.3'	---	---	▽
Casing Pulled	8/10	---	11.1'	---	20.9'	▽
After Drilling	8/13	---	2.9'	---	12.7'	▽

**Ground Surface Elevation:** 326± (ft) **Total Depth:** 48.5 ft

TEST BORING LOG 18C41041 GINT LOGS.GPJ SCHNABEL DATA TEMPLATE 2008\_07\_06.GDT 5/21/19

DEPTH (ft)	MATERIAL DESCRIPTION	SYMBOL	ELEV (ft)	STRATUM	SAMPLING		TESTS	REMARKS
					DEPTH	DATA		
0.4	Asphalt; 5 inches		325.8					
1.0	GRAVEL BASE; 7 inches		325.2					
	FILL, sampled as silty sand; moist, olive brown and brown, contains gravel and mica	FILL		A		S-1, SS 6+4+4 REC=18", 100%	MC = 17.7%	
3.5	SANDY LEAN CLAY; dry to moist, yellowish red and red	CL	322.7	B1	5	S-2, SS 4+5+7 REC=18", 100%	PP = 0.50 tsf	
6.0	CLAYEY SAND; moist, yellowish red, yellowish brown and red		320.2			S-3, SS 7+7+7 REC=18", 100%	MC = 17.0%	
	Change: WITH GRAVEL; yellowish red, yellowish brown, red, and gray	SC		B2	10	S-4, SS 4+4+4 REC=18", 100%		
13.5	SANDY SILT; moist, yellowish brown to yellowish red with mottles of gray and white, estimated 30-45% mica		312.7			S-5, SS 3+4+5 REC=18", 100%	MC = 23.3%	
	Change: reddish brown	ML		C2	20	S-6, SS 7+11+11 REC=18", 100%		
23.5	CLAYEY SAND; moist, yellowish red and yellowish brown with mottles of gray and red and with streaks of black, estimated	SC	302.7			S-7, SS 4+7+8 REC=18", 100%	LL = 47 PL = 23 MC = 29.3%	

(continued)



**TEST BORING LOG**

**Project:** The Catherine and Isiah Leggett Building  
Montgomery College  
7600 Takoma Ave, Takoma Park, Maryland

**Boring Number:** **SB-03**  
**Contract Number:** 18C41041  
**Sheet:** 2 of 2

DEPTH (ft)	MATERIAL DESCRIPTION	SYMBOL	ELEV (ft)	STRATUM	SAMPLING DATA		TESTS	REMARKS
					DEPTH	DATA		
28.5	15-25% mica	SC	297.7				% Passing #200 = 42.4 PP = 1.50 tsf	
	SANDY SILT; moist, yellowish brown with streaks of yellowish red and black, estimated 5-10% mica					S-8, SS 7+8+12 REC=18", 100%		
	Change: gray, black, and light greenish gray, estimated < 5% quartz fragments, estimated 15-25% mica	ML		C2		S-9, SS 18+22+28 REC=18", 100%		
	Change: bluish gray with mottles of black					S-10, SS 18+18+27 REC=18", 100%		
43.5	DISINTEGRATED ROCK, sampled as sandy silt; moist, gray and black with olive streaks, estimated 15-25% mica	DR	282.7	D		S-11, SS 50/5" REC=5", 100%		
48.5			277.7					

Bottom of Boring at 48.5 ft.  
Boring offset 5 ft to the south to avoid concrete. The offset borings has the same elevation as the original location.  
Spoon Refusal at 48.5 ft.

TEST BORING LOG 18C41041 GINT LOGS.GPJ SCHNABEL DATA TEMPLATE 2008\_07\_06.GDT 5/21/19

**Contractor:** Recon Drilling  
 Leesburg, Virginia  
**Contractor Foreman:** W. Rodas  
**Schnabel Representative:** M. Khachan  
**Equipment:** CME 550 ATV  
**Method:** 2-1/4" I.D. Hollow Stem Auger  
  
**Hammer Type:** Auto Hammer (140 lb)  
**Dates Started:** 8/14/18 **Finished:** 8/14/18  
**Location:** See Location Plan  
  
**Ground Surface Elevation:** 331± (ft) **Total Depth:** 51.0 ft

Groundwater Observations					
	Date	Time	Depth	Casing	Caved
Encountered	8/14	---	17.5'	---	---
Completion	8/14	---	40.0'	---	---
Casing Pulled	8/14	---	Dry	---	5.0'
End of Day	8/14	---	Dry	---	5.0'

TEST BORING LOG 18C41041 GINT LOGS.GPJ SCHNABEL DATA TEMPLATE 2008\_07\_06.GDT 5/21/19

DEPTH (ft)	MATERIAL DESCRIPTION	SYMBOL	ELEV (ft)	STRATUM	SAMPLING		TESTS	REMARKS
					DEPTH	DATA		
0.4	Asphalt; 5 inches		330.3					
1.0	GRAVEL BASE; 7 inches		329.7					
	FILL, sampled as sandy silt; moist, brown and black, contains gravel, mica, brick, and organics	FILL		A		S-1, SS 4+4+4 REC=18", 100%		
3.5	PROBABLE FILL, sampled as sandy silt; moist, tan	FILL	327.2		5	S-2, SS 2+12+21 REC=18", 100%		
6.0	SANDY LEAN CLAY; moist, yellowish brown and yellowish red	CL	324.7	B1		S-3, SS 5+7+7 REC=18", 100%	PP = 2.25 tsf	
8.5	CLAYEY SAND; moist, yellowish brown, and red	SC	322.2	B2	10	S-4, SS 3+5+6 REC=18", 100%		
13.5	LEAN CLAY WITH SAND; moist, light gray, streaks of yellowish brown	CL	317.2	B1	15	S-5, SS 3+5+6 REC=18", 100%	PP = 2.25 tsf	
18.5	CLAYEY GRAVEL WITH SAND; wet, yellowish brown, mottles of white	GC	312.2	B2	20	S-6, SS 5+7+12 REC=10", 56%		
23.5	SANDY SILT; moist, yellowish brown, estimated 30-45% mica	ML	307.2	C2		S-7, SS 2+3+3 REC=18", 100%		

(continued)



**Schnabel Engineering DC**  
**TEST BORING LOG**

**Project:** The Catherine and Isiah Leggett Building  
Montgomery College  
7600 Takoma Ave, Takoma Park, Maryland

**Boring Number:** **SB-04**  
**Contract Number:** 18C41041  
**Sheet:** 2 of 2

DEPTH (ft)	MATERIAL DESCRIPTION	SYMBOL	ELEV (ft)	STRATUM	SAMPLING DATA		TESTS	REMARKS
					DEPTH	DATA		
	Change: yellowish brown, black, and gray	ML			30	S-8, SS 8+9+10 REC=18", 100%		
	Change: yellowish red with streaks of black				35	S-9, SS 8+12+13 REC=18", 100%		
38.5	SILTY SAND; moist, bluish gray, black and yellowish red, estimated 30-45% mica	SM	292.2		40	S-10, SS 7+11+17 REC=18", 100%		
43.5	DISINTEGRATED ROCK, sampled as sandy silt; moist, black, bluish gray and olive, estimated 30-45% mica, estimated 10-15% rock fragments and quartz fragments	DR	287.2	D	45	S-11, SS 15+31+50/5" REC=17", 100%		
	Change: estimated 50-100% rock fragments				50	S-12, SS 50/0.5" REC=0.5", 100%		
51.0	Bottom of Boring at 51.0 ft. Spoon Refusal at 51.0 ft.		279.7			S-13, SS 50/0" REC=0"		

TEST BORING LOG 18C41041 GINT LOGS.GPJ SCHNABEL DATA TEMPLATE 2008\_07\_06.GDT 5/21/19

**Contractor:** Recon Drilling  
 Leesburg, Virginia  
**Contractor Foreman:** W. Rodas  
**Schnabel Representative:** M. Khachan  
**Equipment:** CME-45B (Truck)  
**Method:** 2-1/4" I.D. Hollow Stem Auger  
  
**Hammer Type:** Auto Hammer (140 lb)  
**Dates Started:** 8/6/18 **Finished:** 8/6/18  
**Location:** See Location Plan  
  
**Ground Surface Elevation:** 316± (ft) **Total Depth:** 48.7 ft

Groundwater Observations						
	Date	Time	Depth	Casing	Caved	
Encountered	8/6	---	21.0'	---	---	
Completion	8/6	---	10.9'	---	---	
Casing Pulled	8/6	---	6.8'	---	7.2'	
After Drilling	8/7	---	4.6'	---	7.3'	

TEST BORING LOG 18C41041 GINT LOGS.GPJ SCHNABEL DATA TEMPLATE 2008\_07\_06.GDT 5/21/19

DEPTH (ft)	MATERIAL DESCRIPTION	SYMBOL	ELEV (ft)	STRATUM	SAMPLING		TESTS	REMARKS
					DEPTH	DATA		
0.2	Topsoil; 2 inches		315.6	A		S-1, SS 2+2+6+8 REC=10", 42%		
2.0	FILL, sampled as sandy lean clay with gravel; moist, brown, gray, and white, contains brick fragments and roots	FILL	313.8					
	SANDY LEAN CLAY; moist, yellowish brown and gray, estimated < 5% gravel	CL		B1		S-2, SS 2+3+2+3 REC=20", 83%	PP = 0.50 tsf	
	Change: estimated 15-25% gravel				5	S-3, SS 2+3+4+6 REC=24", 100%	PP = 0.75 tsf	
6.0	CLAYEY SAND; moist, light whitish gray, estimated 50 - 100% mica	SC	309.8			S-4, SS 3+2+2+3 REC=18", 75%	LL = 46 PL = 24 MC = 20.9% % Passing #200 = 42.3	
8.0	SANDY SILT; moist, yellowish brown and whitish gray, estimated 30 - 45% mica, est 10-15% rock fragments	ML	307.8			S-5, SS 2+2+2+3 REC=24", 100%		
10.0	SILTY SAND; moist, yellowish brown and light gray with streaks of yellowish red, estimated 30-45% mica	SM	305.8	C2	10	S-6, SS 1+2+3+8 REC=24", 100%		
	Change: brown and yellowish red					S-7, SS 10+19+30+40 REC=24", 100%		
	Change: brown and reddish brown, estimated 10-15% rock fragments				15	S-8, SS 18+20+34+50/5" REC=23", 100%		
15.5	DISINTEGRATED ROCK, sampled as silty sand; moist, brown and reddish brown, estimated 15-25% mica, estimated 15-25% rock fragments	DR	300.3	D	20	S-9, SS 34+50/4" REC=10", 100%		
	Change: brown and grayish brown, with streaks of black and mottles of yellowish red					S-10, SS 50/6" REC=6", 100%		
	Change: brown, gray, olive brown and black							

(continued)



**Schnabel Engineering DC**  
**TEST BORING LOG**

**Project:** The Catherine and Isiah Leggett Building  
Montgomery College  
7600 Takoma Ave, Takoma Park, Maryland

**Boring Number:** SB-05/SWM-4  
**Contract Number:** 18C41041  
**Sheet:** 2 of 2

DEPTH (ft)	MATERIAL DESCRIPTION	SYMBOL	ELEV (ft)	STRATUM	SAMPLING DATA		TESTS	REMARKS
					DEPTH	DATA		
30	Change: moist to wet, brown, yellowish red, yellowish brown, and gray, estimated < 5% mica, no rock fragments		267.2	D	32+50/4"	S-11, SS REC=10", 100%		
35	Change: gray, brown, yellowish red, and black, estimated 15-25% mica, estimated 5-10% rock fragments				50/6"	S-12, SS REC=6", 100%		
40					50/5"	S-13, SS REC=5", 100%		
45	Change: gray, estimated 50 - 100% rock fragments				50/2"	S-14, SS REC=2", 100%		
48.7	Change: olive and bluish gray, no rock fragments				50/2"	S-15, SS REC=2", 100%		
Bottom of Boring at 48.7 ft.								

TEST BORING LOG 18C41041 GINT LOGS.GPJ SCHNABEL DATA TEMPLATE 2008\_07\_06.GDT 5/21/19

**Contractor:** Recon Drilling  
Leesburg, Virginia  
**Contractor Foreman:** U. Rodas  
**Schnabel Representative:** M. Khachan  
**Equipment:** CME 550 ATV  
**Method:** 2-1/4" I.D. Hollow Stem Auger  
**Hammer Type:** Auto Hammer (140 lb)  
**Dates Started:** 8/13/18 **Finished:** 8/13/18  
**Location:** See Location Plan  
**Ground Surface Elevation:** 329± (ft) **Total Depth:** 43.6 ft

Groundwater Observations						
	Date	Time	Depth	Casing	Caved	
Encountered	8/13	---	23.5'	---	---	
Completion	8/13	---	38.5'	---	---	
Casing Pulled	8/13	---	27.5'	---	30.7'	
After Drilling	8/14	---	14.7'	---	19.5'	

TEST BORING LOG 18C41041 GINT LOGS.GPJ SCHNABEL DATA TEMPLATE 2008\_07\_06.GDT 5/21/19

DEPTH (ft)	MATERIAL DESCRIPTION	SYMBOL	ELEV (ft)	STRATUM	SAMPLING		TESTS	REMARKS
					DEPTH	DATA		
0.4	Asphalt; 5 inches		329.0					
1.0	GRAVEL BASE; 7 inches		328.4					
	FILL, sampled as sandy lean clay; moist, brown, black, and gray, contains brick fragments, contains gravel and asphalt	FILL		A		S-1, SS 7+8+8 REC=18", 100%		
3.5	LEAN CLAY WITH SAND; dry to moist, yellowish brown	CL	325.9	B1	5	S-2, SS 2+3+3 REC=18", 100%	PP = 0.75 tsf	
6.0	SILTY SAND; dry to moist, yellowish brown	SM	323.4			S-3, SS 12+17+12 REC=18", 100%		
8.5	CLAYEY SAND WITH GRAVEL; moist, yellowish brown and yellowish red	SC	320.9	B2	10	S-4, SS 5+5+7 REC=18", 100%		
13.5	GRAVELLY LEAN CLAY WITH SAND; moist, yellowish brown, gray, and red	CL	315.9	B1	15	S-5, SS 5+5+10 REC=18", 100%	PP = 2.00 tsf	
						S-6, SS 7+4+4 REC=0", 0%		No Recovery
22.0	SANDY SILT; moist, yellowish brown, light red, and gray, estimated 30-45% mica Change: yellowish brown, black, gray, estimated 15-25% mica	ML	307.4	C2		S-7, SS 7+7+8 REC=18", 100%		
						S-8, SS 7+10+15 REC=18", 100%		Pressurimeter Test conducted at 24

(continued)





**Schnabel Engineering DC**  
**TEST BORING LOG**

**Project:** The Catherine and Isiah Leggett Building  
Montgomery College  
7600 Takoma Ave, Takoma Park, Maryland

**Boring Number:** **SB-06**  
**Contract Number:** 18C41041  
**Sheet:** 2 of 2

DEPTH (ft)	MATERIAL DESCRIPTION	SYMBOL	ELEV (ft)	STRATUM	SAMPLING DATA		TESTS	REMARKS
					DEPTH	DATA		
	Change: yellowish brown, gray, and black, estimated 15-25% mica	ML		C2		S-9, SS 7+10+14 REC=18", 100%		ft.
	Change: yellowish red, mottles of gray					S-10, SS 11+14+17 REC=18", 100%		
	Change: bluish gray and black				30	S-11, SS 9+14+18 REC=18", 100%		
33.5	DISINTEGRATED ROCK, sampled as silty sand with gravel; moist, black and olive, estimated 15-25% rock fragments, estimated 5-10% mica	DR	295.9	D		S-12, SS 50/2" REC=2", 100%		Pressurimeter Test conducted at 27.5 ft.
					35			
					40	S-13, SS 50/1" REC=1", 100%		
43.6	Change: estimated 50-100% rock fragments		285.8			S-14, SS 50/1" REC=1", 100%		
Bottom of Boring at 43.6 ft.								

TEST BORING LOG 18C41041 GINT LOGS.GPJ SCHNABEL DATA TEMPLATE 2008\_07\_06.GDT 5/21/19

**Contractor:** Recon Drilling  
 Leesburg, Virginia  
**Contractor Foreman:** U. Rodas  
**Schnabel Representative:** M. Khachan  
**Equipment:** CME-45B (Truck)  
**Method:** 2-1/4" I.D. Hollow Stem Auger  
  
**Hammer Type:** Auto Hammer (140 lb)  
**Dates Started:** 8/9/18 **Finished:** 8/9/18  
**Location:** See Location Plan  
  
**Ground Surface Elevation:** 328± (ft) **Total Depth:** 43.5 ft

Groundwater Observations						
	Date	Time	Depth	Casing	Caved	
Encountered	8/9	---	18.5'	---	---	
Completion	8/9	---	Dry	---	---	
Casing Pulled	8/9	---	16.0'	---	33.5'	
After Drilling	8/10	---	13.8'	---	19.7'	

TEST BORING LOG 18C41041 GINT LOGS.GPJ SCHNABEL DATA TEMPLATE 2008\_07\_06.GDT 5/21/19

DEPTH (ft)	MATERIAL DESCRIPTION	SYMBOL	ELEV (ft)	STRATUM	SAMPLING		TESTS	REMARKS
					DEPTH	DATA		
0.5	Asphalt; 6 inches		327.5	A				
1.0	GRAVEL BASE; 6 inches		327.0					
1.8	FILL, sampled as sandy lean clay; moist, brown and black, contains gravel, contains brick fragments	FILL	326.2			S-1, SS 2+2+2 REC=18", 100%		
	SANDY LEAN CLAY; moist, yellowish brown Change: mottles of yellowish red, estimated < 5% roots, estimated < 5% gravel	CL		5		S-2, SS 4+6+7 REC=18", 100%	PP = 4.00 tsf	
6.0	LEAN CLAY WITH SAND; moist, yellowish red, red, and gray, estimated <5% gravel Change: no gravel	CL	322.0	B1		S-3, SS 4+5+6 REC=18", 100%	PP = 2.00 tsf	
				10		S-4, SS 4+5+8 REC=18", 100%	PP = 3.00 tsf	
13.5	CLAYEY SAND; moist, yellowish red, yellowish brown, and red, estimated 5-10% gravel	SC	314.5			S-5, SS 4+5+5 REC=18", 100%		
18.5	CLAYEY GRAVEL WITH SAND; wet, light yellowish brown, white, black, and gray	GC	309.5	B2		S-6, SS 7+8+5 REC=3", 17%		
23.5	SANDY SILT; moist, yellowish red, and gray, estimated 30-45% mica	ML	304.5	C2		S-7, SS 2+3+7 REC=18", 100%		

(continued)



**Schnabel Engineering DC**  
**TEST BORING LOG**

**Project:** The Catherine and Isiah Leggett Building  
Montgomery College  
7600 Takoma Ave, Takoma Park, Maryland

**Boring Number:** **SB-07**  
**Contract Number:** 18C41041  
**Sheet:** 2 of 2

DEPTH (ft)	MATERIAL DESCRIPTION	SYMBOL	ELEV (ft)	STRATUM	SAMPLING DATA		TESTS	REMARKS
					DEPTH	DATA		
30	Change: yellowish brown, yellowish red, and gray, estimated 30-45% mica	ML		C2		S-8, SS 8+15+20 REC=18", 100%		
33.5	DISINTEGRATED ROCK, sampled as silty sand; moist, black and gray, estimated 15-25% rock fragments		294.5			S-9, SS 50/2" REC=2", 100%		
40	Change: estimated 50-100% rock fragments	DR		D		S-10, SS 50/1" REC=1", 100%		
43.5	Bottom of Boring at 43.5 ft. Spoon Refusal at 43.5 ft.		284.5			S-11, SS 50/0" REC=0"		

TEST BORING LOG 18C41041 GINT LOGS.GPJ SCHNABEL DATA TEMPLATE 2008\_07\_06.GDT 5/21/19

**Contractor:** Recon Drilling  
 Leesburg, Virginia  
**Contractor Foreman:** U. Rodas  
**Schnabel Representative:** M. Khachan  
**Equipment:** CME-45B (Truck)  
**Method:** 2-1/4" I.D. Hollow Stem Auger  
  
**Hammer Type:** Auto Hammer (140 lb)  
**Dates Started:** 8/7/18 **Finished:** 8/8/18  
**Location:** See Location Plan  
  
**Ground Surface Elevation:** 329± (ft) **Total Depth:** 53.5 ft

Groundwater Observations					
	Date	Time	Depth	Casing	Caved
Encountered	8/8	---	None	---	---
Completion	8/8	---	Dry	---	---
Casing Pulled	8/8	---	Dry	---	29.3'
After Drilling 	8/9	---	20.4'	---	21.5'

TEST BORING LOG 18C41041 GINT LOGS.GPJ SCHNABEL DATA TEMPLATE 2008\_07\_06.GDT 5/21/19

DEPTH (ft)	MATERIAL DESCRIPTION	SYMBOL	ELEV (ft)	STRATUM	SAMPLING		TESTS	REMARKS
					DEPTH	DATA		
0.4	Asphalt; 5 inches		328.7					
1.0	GRAVEL BASE; 7 inches		328.1					
	FILL, sampled as silty sand; moist, olive brown, gray, and black, contains gravel, mica	FILL				S-1, SS 3+10+12 REC=18", 100%		
3.5	FILL, sampled as sandy lean clay with gravel; moist, yellowish brown, contains mica		325.6		5	S-2, SS 4+3+3 REC=18", 100%		
	Change: gray, black, and olive brown, contains brick fragments			A		S-3, SS 2+3+4 REC=18", 100%	LL = 41 PL = 23 MC = 14.5% % Passing #200 = 50.6	
	Change: yellowish brown	FILL			10	S-4, SS 3+1+3 REC=10", 56%		
13.5	CLAYEY SAND; moist, yellowish brown, red and tan	SC	315.6	B2	15	S-5, SS 7+7+8 REC=18", 100%		
18.5	LEAN CLAY WITH SAND; moist, yellowish brown, light gray, and red, estimated <5% gravel	CL	310.6	B1	20	S-6, SS 4+7+9 REC=18", 100%	PP = 2.50 tsf	
23.5	SANDY LEAN CLAY; moist, light brown, gray, and light red, estimated 30-45% mica	CL	305.6	C1		S-7, SS 3+3+3 REC=18", 100%	LL = 49 PL = 24 MC = 22.9%	

(continued)



**TEST BORING LOG**

**Project:** The Catherine and Isiah Leggett Building  
Montgomery College  
7600 Takoma Ave, Takoma Park, Maryland

**Boring Number:** **SB-08**  
**Contract Number:** 18C41041  
**Sheet:** 2 of 2

DEPTH (ft)	MATERIAL DESCRIPTION	SYMBOL	ELEV (ft)	STRATUM	SAMPLING DATA		TESTS	REMARKS
					DEPTH	DATA		
28.5	SANDY SILT; moist, yellowish red and yellowish brown with mottles of light gray and black, esimated 15-25% mcia	CL	300.6	C1			% Passing #200 = 55.9 PP = 1.50 tsf	
	Change: gray, black, and brown with streaks of yellowish red, estimated 30-45% mica	ML		C2	30	S-8, SS 5+7+12 REC=18", 100%		
					35	S-9, SS 6+11+13 REC=18", 100%		
38.5	DISINTEGRATED ROCK, sampled as silty sand; moist, black and gray, estimated 30 - 45% mica		290.6		40	S-10, SS 50/6" REC=6", 100%		
	Change: dry to moist, estimated 50 - 100% rock fragments	DR		D	45	S-11, SS 50/1" REC=1", 100%		
					50	S-12, SS 50/1" REC=1", 100%		
53.5	Bottom of Boring at 53.5 ft.		275.5			S-13, SS 50/0.5" REC=0.5", 100%		

TEST BORING LOG 18C41041 GINT LOGS.GPJ SCHNABEL DATA TEMPLATE 2008\_07\_06.GDT 5/21/19

**Contractor:** Recon Drilling  
 Leesburg, Virginia  
**Contractor Foreman:** U. Rodas  
**Schnabel Representative:** M. Khachan  
**Equipment:** CME-45B (Truck)  
**Method:** 2-1/4" I.D. Hollow Stem Auger  
**Hammer Type:** Auto Hammer (140 lb)  
**Dates Started:** 8/7/18 **Finished:** 8/7/18  
**Location:** See Location Plan  
**Ground Surface Elevation:** 320± (ft) **Total Depth:** 52.6 ft

Groundwater Observations						
	Date	Time	Depth	Casing	Caved	
Encountered	8/7	---	26.0'	---	---	
Completion	8/7	---	23.7'	---	---	
Casing Pulled	8/7	---	40.5'	---	PIPE	
After Drilling	8/8	---	15.3'	---	PIPE	

TEST BORING LOG 18C41041 GINT LOGS.GPJ SCHNABEL DATA TEMPLATE 2008\_07\_06.GDT 5/21/19

DEPTH (ft)	MATERIAL DESCRIPTION	SYMBOL	ELEV (ft)	STRATUM	SAMPLING		TESTS	REMARKS
					DEPTH	DATA		
0.3	Topsoil; 3 inches FILL, sampled as sandy silt with gravel; moist, brown, contains roots  Change: yellowish brown and brown	FILL	319.6	A		S-1, SS 2+3+3 REC=10", 56%		
5.0	SANDY LEAN CLAY; moist, yellowish brown, estimated 5-10% gravel, estimated < 5% roots	CL	314.8	B1	5	S-2, SS 7+11+12 REC=18", 100%	MC = 9.6%	
8.5	CLAYEY SAND; moist, yellowish brown, yellowish red, and gray, estimated 5-10% gravel	SC	311.3	B2	10	S-3, SS 2+3+5 REC=18", 100%	PP = NA tsf	
13.5	CLAYEY SAND; moist, yellowish brown, yellowish red, and gray, estimated 5-10% gravel	SC	311.3	B2	10	S-4, SS 4+9+11 REC=18", 100%	LL = 39 PL = 25 MC = 14.7% % Passing #200 = 27.5	
13.5	SANDY LEAN CLAY; moist, white, gray, and yellowish brown, estimated 5-10% gravel	CL	306.3	B1	15	S-5, SS 3+4+5 REC=18", 100%	PP = 1.25 tsf	
18.5	SILTY SAND WITH GRAVEL; moist to wet, light brown, yellowish brown, and gray, estimated 30-45% mica, estimated 15-25% quartz fragment and and quartz gravel	SM	301.3	C2	20	S-6, SS 3+7+5 REC=18", 100%		
23.5	SILTY SAND; moist, yellowish brown and reddish brown, estimated 15 - 25% mica	SM	296.3			S-7, SS 7+9+11 REC=18", 100%		

(continued)



**TEST BORING LOG**

**Project:** The Catherine and Isiah Leggett Building  
Montgomery College  
7600 Takoma Ave, Takoma Park, Maryland

**Boring Number:** SB-09  
**Contract Number:** 18C41041  
**Sheet:** 2 of 2

DEPTH (ft)	MATERIAL DESCRIPTION	SYMBOL	ELEV (ft)	STRATUM	SAMPLING DATA		TESTS	REMARKS
					DEPTH	DATA		
28.5	DISINTEGRATED ROCK, sampled as silty sand; moist, bluish gray and black, estimated 30-45% mica, estimated 5-10% rock fragments	SM	291.3	C2	30	S-8, SS 19+30+44 REC=18", 100%		
	Change: olive gray, yellowish brown, and black				35	S-9, SS 29+40+50 REC=18", 100%		
	Change: gray and black, estimated 15 - 25% rock fragments				40	S-10, SS 30+45+50/4" REC=16", 100%		
	Change: brown and gray	DR		D	45	S-11, SS 50/2" REC=2", 100%		
	Change: yellowish brown, yellowish red, gray, and black, estimated 15-25% mica				50	S-12, SS 32+25+27 REC=18", 100%		
52.6	Change: brown, gray, and black, estimated 50-100% rock fragments  Bottom of Boring at 52.6 ft.		267.2			S-13, SS 50/1" REC=1", 100%		

TEST BORING LOG 18C41041 GINT LOGS.GPJ SCHNABEL DATA TEMPLATE 2008\_07\_06.GDT 5/21/19



**Project:** The Catherine and Isiah Leggett Building  
 Montgomery College  
 7600 Takoma Ave, Takoma Park, Maryland

**Boring Number:** **SB-10**  
**Contract Number:** 18C41041  
**Sheet:** 1 of 2

**Contractor:** Recon Drilling  
 Leesburg, Virginia  
**Contractor Foreman:** U. Rodas  
**Schnabel Representative:** M. Khachan  
**Equipment:** CME-45B (Truck)  
**Method:** 2-1/4" I.D. Hollow Stem Auger  
  
**Hammer Type:** Auto Hammer (140 lb)  
**Dates Started:** 8/9/18 **Finished:** 8/9/18  
**Location:** See Location Plan  
  
**Ground Surface Elevation:** 326± (ft) **Total Depth:** 43.8 ft

Groundwater Observations						
	Date	Time	Depth	Casing	Caved	
Encountered	8/9	---	23.7'	---	---	
Completion	8/9	---	35.4'	---	---	
Casing Pulled	8/9	---	Dry	---	18.1'	
After Drilling	8/10	---	9.6'	---	11.1'	

TEST BORING LOG 18C41041 GINT LOGS.GPJ SCHNABEL DATA TEMPLATE 2008\_07\_06.GDT 5/21/19

DEPTH (ft)	MATERIAL DESCRIPTION	SYMBOL	ELEV (ft)	STRATUM	SAMPLING		TESTS	REMARKS
					DEPTH	DATA		
0.4	Asphalt; 5 inches		326.0					
1.0	GRAVEL BASE; 7 inches		325.4					
	FILL, sampled as clayey sand with gravel; moist, gray and brown, contains quartz fragments, mica and rock fragments	FILL				S-1, SS 3+7+4 REC=6", 33%		
3.5	FILL, sampled as sandy silt; moist, brown, gray, and black, contains gravel, rock fragments and mica	FILL	322.9		5	S-2, SS 1+2+3 REC=5", 28%		
	Change: olive brown and gray	FILL				S-3, SS 3+4+4 REC=18", 100%		Potential Chemical Odor
8.5	FILL, sampled as sandy lean clay; moist, brown and black, contains gravel, mica, glass fragments, and organics	FILL	317.9		10	S-4, SS 2+2+2 REC=18", 100%		
	Change: yellowish brown and gray	FILL		A		S-5, SS 1+2+4 REC=8", 44%		
15		FILL			15			
18.5	PROBABLE FILL, sampled as clayey gravel; moist, yellowish brown and white	FILL	307.9		20	S-6, SS 1+2+3 REC=4", 22%		
23.5	CLAYEY SAND; moist, yellowish brown and yellowish red, streaks of white	SC	302.9	B2		S-7, SS 2+3+3 REC=18", 100%		

(continued)



DEPTH (ft)	MATERIAL DESCRIPTION	SYMBOL	ELEV (ft)	STRATUM	SAMPLING DATA		TESTS	REMARKS
					DEPTH	DATA		
28.5	ELASTIC SILT WITH SAND; moist to wet, yellowish brown with streaks of yellowish red, estimated 10-15% mica	SC	297.9	B2	30	S-8, SS 5+8+12 REC=18", 100%	PP = 2.50 tsf	
33.5	SANDY SILT; moist, black and bluish gray, estimated 30 - 45% mica	MH	292.9	C1	35	S-9, SS 12+18+25 REC=18", 100%		
38.5	DISINTEGRATED ROCK, sampled as sandy silt; moist, black, bluish gray, and brown, estimated 30-45% mica, estimated 10-15% rock fragments	ML	287.9	C2	40	S-10, SS 16+31+47 REC=18", 100%		
43.8	Change: brown and gray Bottom of Boring at 43.8 ft.	DR	282.7	D		S-11, SS 50/3" REC=3", 100%		

TEST BORING LOG 18C41041 GINT LOGS.GPJ SCHNABEL DATA TEMPLATE 2008\_07\_06.GDT 5/21/19

**Contractor:** Recon Drilling  
Leesburg, Virginia  
**Contractor Foreman:** U. Rodas  
**Schnabel Representative:** M. Khachan  
**Equipment:** CME-45B (Truck)  
**Method:** 2-1/4" I.D. Hollow Stem Auger  
**Hammer Type:** Auto Hammer (140 lb)  
**Dates Started:** 8/8/18 **Finished:** 8/8/18  
**Location:** See Location Plan  
**Ground Surface Elevation:** 326± (ft) **Total Depth:** 15.8 ft

Groundwater Observations						
	Date	Time	Depth	Casing	Caved	
Encountered	8/8	---	13.0'	---	---	
Completion	8/8	---	13.7'	---	---	
Casing Pulled	8/8	---	Dry	---	4.5'	
After Drilling	8/9	---	Dry	---	4.1'	

DEPTH (ft)	MATERIAL DESCRIPTION	SYMBOL	ELEV (ft)	STRATUM	SAMPLING		TESTS	REMARKS
					DEPTH	DATA		
0.3	Topsoil; 4 inches		325.9	A		S-1, SS 2+3+2+3 REC=24", 100%	LL = 36 PL = 23 MC = 7.4% % Passing #200 = 15.5	
2.0	FILL, sampled as sandy lean clay; moist, yellowish brown, contains roots and gravel	FILL	324.2			S-2, SS 3+4+5+9 REC=24", 100%		
	CLAYEY SAND; moist, yellowish brown and red, estimated 5 - 10% gravel, estimated <5% roots	SC		5	S-3, SS 3+8+14+16 REC=24", 100%			
	Change: WITH GRAVEL; yellowish red, yellowish brown and white					S-4, SS 9+12+16+21 REC=18", 75%		
6.0	CLAYEY SAND WITH GRAVEL; moist, yellowish brown and yellowish red	SC	320.2	B2	10	S-5, SS 8+12+16+16 REC=3", 13%		
	Change: yellowish brown							
					15	S-7, SS 9+11+13+10 REC=14", 58%		
						S-8, SS 4+5+16+50/4" REC=20", 91%		
15.8			310.4					

Bottom of Boring at 15.8 ft.  
Offset 4 ft to the east and auger probed for infiltration testing. PVC pipe installed to 6.0 ft.

**Contractor:** Recon Drilling  
 Leesburg, Virginia  
**Contractor Foreman:** U. Rodas  
**Schnabel Representative:** M. Khachan  
**Equipment:** CME-45B (Truck)  
**Method:** 2-1/4" I.D. Hollow Stem Auger  
  
**Hammer Type:** Auto Hammer (140 lb)  
**Dates Started:** 8/6/18 **Finished:** 8/6/18  
**Location:** See Location Plan  
  
**Ground Surface Elevation:** 326± (ft) **Total Depth:** 15.0 ft

Groundwater Observations					
	Date	Time	Depth	Casing	Caved
Encountered	8/6	---	None	---	---
Completion	8/6	---	Dry	---	---
Casing Pulled	8/6	---	Dry	---	10.0'
After Drilling	8/6	---	Dry	---	2.0'

DEPTH (ft)	MATERIAL DESCRIPTION	SYMBOL	ELEV (ft)	STRATUM	SAMPLING DATA		TESTS	REMARKS
					DEPTH	DATA		
0.4	Asphalt; 5 inches		326.1					
1.0	GRAVEL BASE; 7 inches		325.5					
	FILL, sampled as sandy silt with gravel; moist, brown, contains roots and asphalt	FILL		A		S-1, SS 2+3+3+3 REC=20", 83%		
3.0	PROBABLE FILL, sampled as clayey sand with gravel; moist, yellowish brown and dark red	FILL	323.5			S-2, SS 1+1+3+4 REC=18", 75%		
5.0	CLAYEY SAND; moist, yellowish red and yellowish brown, estimated < 5% roots, estimated < 5% gravel		321.5		5	S-3, SS 1+3+7+9 REC=18", 75%	LL = 34 PL = 21 MC = 13.3% % Passing #200 = 31.7	
	Change: no roots, no gravel	SC				S-4, SS 7+8+10+11 REC=24", 100%		
	Change: estimated < 5% thin, light gray clay seams			B2	10	S-5, SS 7+8+9+9 REC=24", 100%		
11.0	POORLY GRADED SAND WITH SILT; moist, yellowish red and yellowish brown		315.5			S-6, SS 4+6+7+7 REC=24", 100%		
	Change: yellowish brown and gray	SP-SM				S-7, SS 4+5+6+6 REC=24", 100%		
15.0			311.5		15			

Bottom of Boring at 15.0 ft.  
 Offset 5 ft to the west and auger probed for infiltration testing. PVC pipe installed to 6.0 ft.



**Project:** The Catherine and Isiah Leggett Building  
 Montgomery College  
 7600 Takoma Ave, Takoma Park, Maryland

**Boring Number:** **SWM-3**  
**Contract Number:** 18C41041  
**Sheet:** 1 of 1

**Contractor:** Recon Drilling  
 Leesburg, Virginia  
**Contractor Foreman:** U. Rodas  
**Schnabel Representative:** M. Khachan  
**Equipment:** CME-45B (Truck)  
**Method:** 2-1/4" I.D. Hollow Stem Auger  
**Hammer Type:** Auto Hammer (140 lb)  
**Dates Started:** 8/8/18 **Finished:** 8/8/18  
**Location:** See Location Plan  
**Ground Surface Elevation:** 324± (ft) **Total Depth:** 16.0 ft

Groundwater Observations					
	Date	Time	Depth	Casing	Caved
Encountered	8/8	---	None	---	---
Completion	8/8	---	Dry	---	---
Casing Pulled	8/8	---	Dry	---	1.3'
After Drilling	8/9	---	Dry	---	1.1'





DEPTH (ft)	MATERIAL DESCRIPTION	SYMBOL	ELEV (ft)	STRATUM	SAMPLING		TESTS	REMARKS
					DEPTH	DATA		
0.4	Topsoil; 4 inches		324.1			S-1, SS 2+3+4+4 REC=18", 75%		
2.0	FILL, sampled as clayey sand with gravel; moist, dark brown and reddish brown, contains brick fragments and roots	FILL	322.5	A		S-2, SS 6+5+6+11 REC=24", 100%		
4.0	FILL, sampled as sandy lean clay with gravel; moist, yellowish brown, contains roots	FILL	320.5			S-3, SS 3+12+15+18 REC=12", 50%	PP = 3.50 tsf	
6.0	SANDY LEAN CLAY WITH GRAVEL; moist, dark yellowish brown and yellowish red	CL	318.5	B1	5	S-4, SS 3+5+12+21 REC=14", 58%	LL = 35 PL = 21 MC = 10.5% % Passing #200 = 26.3	
	Change: yellowish red and white	SC				S-5, SS 12+11+11+19 REC=24", 100%		
10.0	CLAYEY SAND WITH GRAVEL; moist, yellowish red and yellowish brown	SC	314.5	B2	10	S-6, SS 6+15+8+10 REC=24", 100%		
12.0	SANDY SILT; moist, yellowish brown and gray, estimated 30 - 45% mica	ML	312.5			S-7, SS 4+4+4+5 REC=18", 75%		
						S-8, SS 2+4+5+5 REC=24", 100%		
16.0			308.5	C2	15			

Bottom of Boring at 16.0 ft.  
 Offset 5 ft to the east and auger probed for infiltration testing. PVC pipe installed to 6.0 ft.

TEST BORING LOG 18C41041 GINT LOGS.GPJ SCHNABEL DATA TEMPLATE 2008\_07\_06.GDT 5/21/19

**Contractor:** Recon Drilling  
 Leesburg, Virginia  
**Contractor Foreman:** U. Rodas  
**Schnabel Representative:** M. Khachan  
**Equipment:** CME-45B (Truck)  
**Method:** 2-1/4" I.D. Hollow Stem Auger  
  
**Hammer Type:** Auto Hammer (140 lb)  
**Dates Started:** 8/7/18 **Finished:** 8/7/18  
**Location:** See Location Plan  
  
**Ground Surface Elevation:** 315± (ft) **Total Depth:** 16.0 ft

Groundwater Observations					
	Date	Time	Depth	Casing	Caved
Encountered	8/7	---	None	---	---
Completion	8/7	---	Dry	---	---
Casing Pulled	8/7	---	Dry	---	7.2'
After Drilling 	8/8	---	6.0'	---	6.8'

DEPTH (ft)	MATERIAL DESCRIPTION	SYMBOL	ELEV (ft)	STRATUM	SAMPLING		TESTS	REMARKS
					DEPTH	DATA		
0.3	Topsoil; 3 inches		314.8	A		S-1, SS 2+1+1+3 REC=20", 83%		
	FILL, sampled as sandy lean clay; moist, brown, contains roots	FILL						
2.0	SANDY LEAN CLAY; moist, yellowish brown with mottles of light gray, estimated < 5% gravel		313.0	B1		S-2, SS 1+3+3+8 REC=24", 100%	PP = 2.40 tsf	
	Change: estimated <5% roots							
6.0	LEAN CLAY WITH SAND; moist, yellowish brown with mottles of light gray and yellowish red, no roots	CL	309.0		5	S-3, SS 7+7+9+11 REC=24", 100%	PP = 2.50 tsf	
	Change: gray, yellowish brown, and reddish brown, estimated 10-15% gravel, estimated <5% mica	CL			S-4, SS 3+4+7+9 REC=24", 100%	LL = 40 PL = 25 MC = 12.0% % Passing #200 = 81.5 PP = 3.50 tsf PP = 3.50 tsf		
10.0	SANDY FAT CLAY WITH GRAVEL; moist, whitish brown, yellowish gray, brown, and red, estimated <5% mica		305.0	10	S-5, SS 4+7+9+11 REC=24", 100%	PP =NA tsf		
			CH			S-6, SS 4+5+9+11 REC=10", 42%		
14.0	SILTY SAND; moist, yellowish brown, estimated 5 - 10% mica		301.0	C2	15	S-7, SS 3+3+5+5 REC=0", 0%		No Recovery
			SM				S-8, SS 5+4+5+6 REC=12", 50%	
16.0			299.0					

Bottom of Boring at 16.0 ft.  
 Offset 5 ft to the north east and auger probed for infiltration testing. Pipe installed to 6.0 ft.

TEST BORING LOG 18C41041 GINT LOGS.GPJ SCHNABEL DATA TEMPLATE 2008\_07\_06.GDT 5/21/19

**Contractor:** Recon Drilling  
Leesburg, Virginia  
**Contractor Foreman:** U. Rodas  
**Schnabel Representative:** M. Khachan  
**Equipment:** CME-45B (Truck)  
**Method:** 2-1/4" I.D. Hollow Stem Auger  
**Hammer Type:** Auto Hammer (140 lb)  
**Dates Started:** 8/8/18 **Finished:** 8/8/18  
**Location:** See Location Plan  
**Ground Surface Elevation:** 329± (ft) **Total Depth:** 15.0 ft

Groundwater Observations					
	Date	Time	Depth	Casing	Caved
Encountered	8/8	---	Ne	---	---
Completion	8/8	---	Dry	---	---
Casing Pulled	8/8	---	Dry	---	2.5'
After Drilling	8/9	---	Dry	---	2.0'

DEPTH (ft)	MATERIAL DESCRIPTION	SYMBOL	ELEV (ft)	STRATUM	SAMPLING DATA		TESTS	REMARKS
					DEPTH	DATA		
0.5	Asphalt; 6 inches		328.4					
1.0	GRAVEL BASE; 6 inches		327.9					
	CLAYEY SAND; moist, yellowish brown, estimated <5% gravel	SC				S-1, SS 9+9+9+9 REC=24", 100%	LL = 37 PL = 22 MC = 11.1% % Passing #200 = 28.3	
	Change: yellowish brown and yellowish red					S-2, SS 5+7+9+12 REC=24", 100%		
	Change: yellowish brown and light reddish brown				5	S-3, SS 3+8+9+11 REC=24", 100%		
7.0	CLAYEY GRAVEL WITH SAND; moist, yellowish red, yellowish brown, and white	GC	321.9	B2		S-4, SS 9+14+13+14 REC=24", 100%		
	Change: yellowish brown and white					S-5, SS 6+14+15+18 REC=6", 25%		
	Change: yellowish brown, white, and gray				10	S-6, SS 6+12+30+50/5" REC=12", 50%		
	Change: yellowish brown and white					S-7, SS 32+12+12+12 REC=14", 58%		
15.0			313.9		15			

Bottom of Boring at 15.0 ft.  
Boring was offset 9 ft North from the original location due to electrical lines above the original location, and a sewer line 5 ft from the original location. No elevation change.  
Infiltration boring was offset 4 ft to the north. Pipe installed to 6.0 ft.

**Contractor:** Recon Drilling  
Leesburg, Virginia  
**Contractor Foreman:** U. Rodas  
**Schnabel Representative:** M. Khachan  
**Equipment:** CME 550 ATV  
**Method:** 2-1/4" I.D. Hollow Stem Auger  
  
**Hammer Type:** Auto Hammer (140 lb)  
**Dates Started:** 8/13/18 **Finished:** 8/13/18  
**Location:** See Location Plan  
  
**Ground Surface Elevation:** 316± (ft) **Total Depth:** 15.0 ft

Groundwater Observations						
	Date	Time	Depth	Casing	Caved	
Encountered	8/8	---	10.5'	---	---	
Completion	8/8	---	7.9'	---	---	
Casing Pulled	8/8	---	7.8'	---	11.0'	

DEPTH (ft)	MATERIAL DESCRIPTION	SYMBOL	ELEV (ft)	STRATUM	SAMPLING DATA		TESTS	REMARKS
					DEPTH	DATA		
0 - 8.5	No SPT samples were collected. Augered to 8.5 ft.							
8.5	SILTY SAND; moist, whitish gray, contains 50-100% mica	SM	307.3	C2	9.5 - 10.0	S-1, SS 4+4+3 REC=9", 50%	PP = 0.50 tsf	Pressurimeter Test conducted at 10.5 ft.
10.0	Change: yellowish brown, with mottles of black, contains 15-25% mica				10.0 - 10.5	S-2, SS 1+1+3 REC=18", 100%	PP = 0.50 tsf	
13.5	DISINTEGRATED ROCK, sampled as silty sand; moist, yellowish red, brown, and black, estimated 30-45% mica, estimated 15-25% rock fragments	DR	302.3	D	13.0 - 13.5	S-3, SS 15+25+34 REC=18", 100%		
15.0	Bottom of Boring at 15.0 ft.		300.8		14.5 - 15.0	S-4, SS 21+30+31 REC=18", 100%		

SB-05 (PMT) is a pressuremeter test boring that was drilled 3 ft to the SW of the original SB-05/SWM-4 boring location, and at the same ground elevation.

TEST BORING LOG 18C41041 GINT LOGS.GPJ SCHNABEL DATA TEMPLATE 2008\_07\_06.GDT 5/21/19



**Project:** The Catherine and Isiah Leggett Building  
 Montgomery College  
 7600 Takoma Ave, Takoma Park, Maryland

**Boring Number:** **Boring A**  
**Contract Number:** 18C41041  
**Sheet:** 1 of 2

**Contractor:** Connelly and Associates, Inc.  
 Frederick, Maryland

**Contractor Foreman:** Josh Lewis

**Schnabel Representative:** M. Khachan

**Equipment:** Acker Scout Rig

**Method:** 2-1/4" I.D. Hollow Stem Auger

**Hammer Type:** Manual

**Dates Started:** 5/15/19 **Finished:** 5/15/19

**Location:** See Location Plan

**Ground Surface Elevation:** 329± (ft) **Total Depth:** 38.8 ft

**Groundwater Observations**

	Date	Time	Depth	Casing	Caved
Encountered ▽	5/15	---	20.0'	---	---
Completion ▼	5/15	---	22.0'	---	---
Casing Pulled	5/15	---	Dry	---	4.0'
After Drilling	5/16	---	Dry	---	4.0'

TEST BORING LOG 18C41041 GINT LOGS.GPJ SCHNABEL DATA TEMPLATE 2008\_07\_06.GDT 5/21/19

DEPTH (ft)	MATERIAL DESCRIPTION	SYMBOL	ELEV (ft)	STRATUM	SAMPLING		TESTS	REMARKS
					DEPTH	DATA		
1.0	Asphalt; 12 inches (no gravel base)							
	FILL, sampled as silty sand; moist, yellowish brown, gray, black, and white, contains gravel and mica	FILL	327.5			S-1, SS 1+2+2+3 REC=18", 75%		
3.0	FILL, sampled as sandy lean clay; moist, olive brown, contains mica and gravel	FILL	325.5	A		S-2, SS 11+3+3+4 REC=8", 33%		
5.0	SANDY LEAN CLAY; moist, yellowish brown, yellowish red, and red, estimated <5% cemented sand	CL	323.5	B1	5	S-3, SS 3+4+7+8 REC=16", 67%	PP = 1.75 tsf	
7.0	CLAYEY SAND WITH GRAVEL; moist, yellowish brown, yellowish red, and white, estimated <5% mica, estimated 5-10% cemented sand	SC	321.5			S-4, SS 5+7+9+15 REC=24", 100%		
9.0	CLAYEY GRAVEL WITH SAND; moist, yellowish brown with mottles of yellowish red and gray, estimated 20-30% quartz gravel	GC	319.5		10	S-5, SS 27+32+36+37 REC=24", 100%		
13.5	CLAYEY SAND WITH GRAVEL; moist, yellowish brown and yellowish red	SC	315.0	B2	15	S-6, SS 18+23+27 REC=4", 22%		
18.5	SILTY SAND; moist, yellowish brown with speckles of light tan, estimated 10-15% mica	SM	310.0	C2	20	S-7, SS 15+22+21 REC=8", 44%		
23.5	SANDY LEAN CLAY; very moist to wet, yellowish brown, estimated 10-15% mica, estimated 5-10% rock fragments	CL	305.0	C1		S-8, SS 15+21+28 REC=11", 61%	PP = 0.25 tsf	

(continued)





**Schnabel Engineering DC**  
**TEST BORING LOG**

**Project:** The Catherine and Isiah Leggett Building  
Montgomery College  
7600 Takoma Ave, Takoma Park, Maryland

**Boring Number:** **Boring A**  
**Contract Number:** 18C41041  
**Sheet:** 2 of 2

DEPTH (ft)	MATERIAL DESCRIPTION	SYMBOL	ELEV (ft)	STRATUM	SAMPLING DATA		TESTS	REMARKS
					DEPTH	DATA		
28.5	DISINTEGRATED ROCK, sampled as silty sand; moist, yellowish brown and gray, estimated 10-15% mica	CL	300.0	C1	30	S-9, SS 21+50/6" REC=12", 100%		
33.5	DISINTEGRATED ROCK, sampled as sandy silt; moist, yellowish brown, yellowish red, black and white, estimated 10-15% mica	DR	295.0	D	35	S-10, SS 50/2" REC=2", 100%		
38.5 38.8	DISINTEGRATED ROCK, sampled as silty sand; moist, gray, black, and greenish gray, estimated 10-15% mica	DR	290.0 289.7			S-11, SS 50/4" REC=4", 100%		

Bottom of Boring at 38.8 ft.  
Boring was backfilled with spoils and asphalt was patched .  
PP= pocket penetrometer (unconfined compressive strength).

TEST BORING LOG 18C41041 GINT LOGS.GPJ SCHNABEL DATA TEMPLATE 2008\_07\_06.GDT 5/21/19



**Project:** The Catherine and Isiah Leggett Building  
 Montgomery College  
 7600 Takoma Ave, Takoma Park, Maryland

**Boring Number:** **Boring B**  
**Contract Number:** 18C41041  
**Sheet:** 1 of 2

**Contractor:** Connelly and Associates, Inc.  
 Frederick, Maryland

**Contractor Foreman:** Josh Lewis

**Schnabel Representative:** S. Offutt

**Equipment:** Acker Scout Rig

**Method:** 2-1/4" I.D. Hollow Stem Auger

**Hammer Type:** Manual

**Dates Started:** 5/16/19 **Finished:** 5/16/19

**Location:** See Location Plan

**Ground Surface Elevation:** 316± (ft) **Total Depth:** 34.0 ft

**Groundwater Observations**

	Date	Time	Depth	Casing	Caved
Encountered	5/16	---	None	---	---
Completion	5/16	---	Dry	---	---
Casing Pulled	5/16	---	27.9'	---	28.0'
End of Day	5/16	---	27.9'	---	28.0'

TEST BORING LOG 18C41041 GINT LOGS.GPJ SCHNABEL DATA TEMPLATE 2008\_07\_06.GDT 5/21/19

DEPTH (ft)	MATERIAL DESCRIPTION	SYMBOL	ELEV (ft)	STRATUM	SAMPLING		TESTS	REMARKS
					DEPTH	DATA		
0.7	Concrete; 8 inches		315.7	A				
1.2	FILL, sampled as silty gravel with sand; moist, yellowish brown with mottles of brown	FILL	315.2	B1		S-1, SS 3+5+21+30 REC=24", 100% SS	PP = 4.00 tsf	
3.0	SANDY LEAN CLAY; moist, yellowish brown with mottles of brown, estimated 5-10% gravel, estimated <5% mica	CL	313.4			S-2, SS 10+13+14+7 REC=18", 75%		
5.0	CLAYEY GRAVEL WITH SAND; moist, brown, yellowish brown, and reddish brown	GC	311.4	B2	5	S-3, SS 18+13+12+10 REC=18", 75%	PP = NA tsf	
	CLAYEY SAND WITH GRAVEL; moist, yellowish brown and light brown	SC						
7.0	SANDY SILT; moist, yellowish brown and light brown with speckles of gray, estimated 5-10% rock fragments, estimated 5-10% mica	ML	309.4	C2		S-4, SS 10+18+24+36 REC=24", 100%		
9.0	DISINTEGRATED ROCK, sampled as sandy silt; moist, yellowish brown and yellowish red, streaks of black, estimated <5% mica	DR	307.4	D	10	S-5, SS 16+26+37+50/4" REC=23", 105%		
13.5	SANDY SILT; moist, yellowish brown, mottles of red and gray, estimated 5-10% mica	ML	302.9	C2	15	S-6, SS 8+13+18 REC=18", 100%		
18.5	DISINTEGRATED ROCK, sampled as sandy silt; moist, bluish gray with mottles of dark gray, estimated 5-10% mica, estimated 5-10% quartz fragments	DR	297.9	D	20	S-7, SS 17+27+34 REC=18", 100%		
	Change: olive, yellowish brown, reddish brown, and black					S-8, SS 28+50/4" REC=10", 100%		

(continued)



**Schnabel Engineering DC**  
**TEST BORING LOG**

**Project:** The Catherine and Isiah Leggett Building  
Montgomery College  
7600 Takoma Ave, Takoma Park, Maryland

**Boring Number:** **Boring B**  
**Contract Number:** 18C41041  
**Sheet:** 2 of 2

DEPTH (ft)	MATERIAL DESCRIPTION	SYMBOL	ELEV (ft)	STRATUM	SAMPLING DATA		TESTS	REMARKS
					DEPTH	DATA		
28.5	DISINTEGRATED ROCK, sampled as silty sand; moist, gray with mottles of white, estimated 20-30% rock fragments	DR	287.9	D	30	S-9, SS 50/2" REC=2", 100%		
34.0		DR				S-10, SS 50/1" REC=1", 100%		
Change: 50-100% rock fragments			282.4			S-11, SS 50/0" REC=0"		
<p>Bottom of Boring at 34.0 ft.            Boring was backfilled with spoils and concrete was patched.            Auger and spoon refusal at 34.0 ft.            PP= pocket penetrometer (unconfined compressive strength).            NA= reading could not be obtained from sample.</p>								

# APPENDIX B

## IN-SITU TEST RESULTS

Pressuremeter Test Method (1 sheet)  
Pressuremeter Test Curves (3 sheets)

# PRESSUREMETER TEST METHOD

## Brief Description of the Pressuremeter Test

The test is performed in a borehole with a short cylindrical metal probe covered with a rubber membrane. The probe is inflated with water under pressure from a surface control apparatus. Pressure is increased in steps and deformations are recorded. The procedure represents a load test on the walls of the borehole. Volume changes for a particular loading step are recorded at 30 seconds and one minute after load application.

## Results of Pressuremeter Tests

The tests furnish information relating to the undrained shear strength and deformation characteristics of the material. Results provide a basis to predict bearing capacity and settlement of foundations.

The result of the test is the Pressuremeter curve. The curve shows a volume increase of the probe versus the pressure applied considering readings at the end of each loading step. This curve also represents the deformation of the soil under lateral radial stresses. The initial portion represents the adjustments of the probe to the borehole and to the restoration of the original horizontal pressures. The straight-line portion of the curve that follows is the elastic deformation of the soil and can be measured by the slope of the line, resulting in the Pressuremeter Modulus  $E_P$ . This modulus is evaluated for each test and is shown in units of tons per square foot. The Pressuremeter Modulus is similar to the Modulus of Elasticity except it is measured in the horizontal direction. Rheological corrections for isotropy are necessary in most soils to obtain elasticity in the vertical direction.

After the straight-line portion, the Pressuremeter curve shows an increased rate of deformation in the range of plastic deformations, and the curve approaches a limit pressure where no further loading is necessary to cause continuous volume change. This pressure is estimated as the vertical asymptote of the Pressuremeter curve and is presented as the Limit Pressure in units of tons per square foot.

# Schnabel Engineering

## Pressuremeter Test Results

<b>Project Name:</b> Montgomery Coll. Math and Sci. Bldg.	<b>Schnabel Rep.:</b> M.S.
<b>Location:</b> Takoma Park, Maryland	<b>Date:</b> 8/13/2018
<b>Contract No.:</b> 18C41041	

### Pressuremeter Test Curves

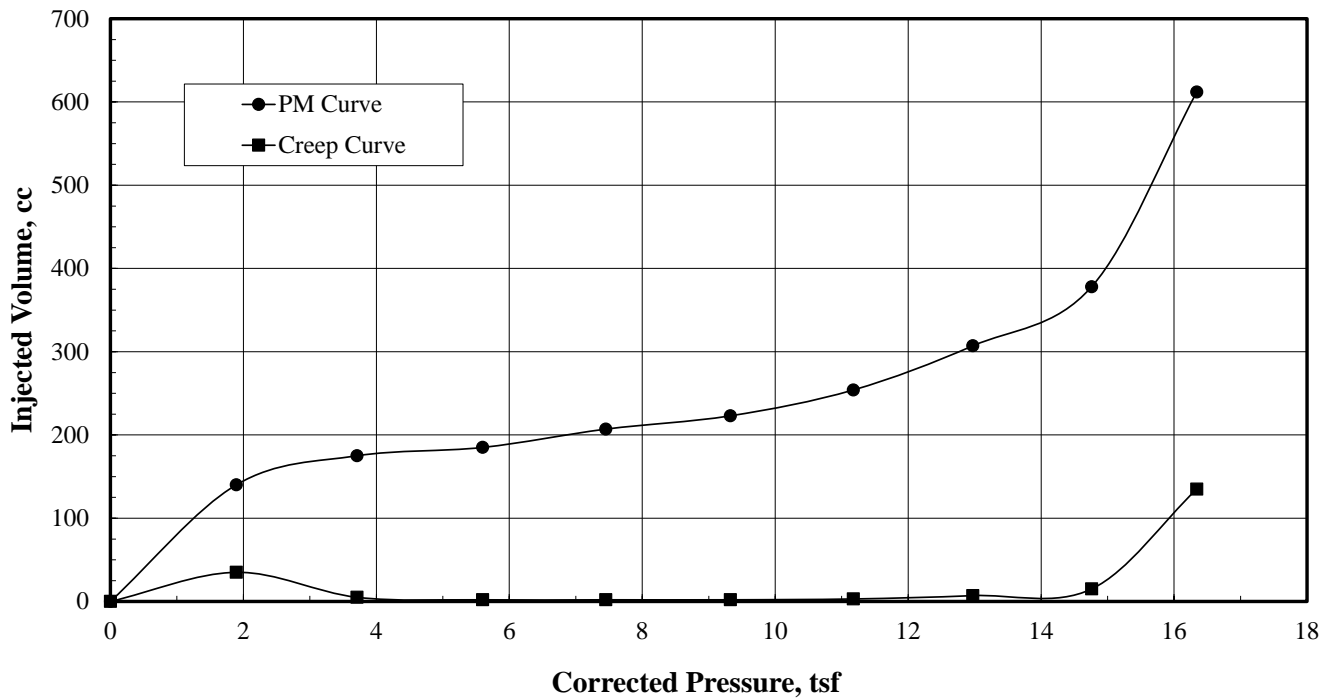

### Pressuremeter Test Data

<b>Boring No.:</b> SB-5	<b>Ground Surface Elevation:</b> 315.8 ft
<b>Test No.:</b> 2	<b>Test Elevation:</b> 301.8 ft
<b>Test Depth:</b> 14	<b>Ground Water Elevation:</b> 307.8 ft
<b>Soil Description:</b> Sandy Silt, orangish brown, wet, contains mica and rock fragments (Disintegrated Rock)	
<b>Geology:</b> Residual	<b>Soil Classification:</b> ML
<b>N-Value:</b> 61	
<b>Pressuremeter Modulus:</b> 308 tsf	
<b>Estimated Limit Pressure:</b> 18 (Visual Estimate Only)	

# Schnabel Engineering

## Pressuremeter Test Results

<b>Project Name:</b> Montgomery Coll. Math and Sci. Bldg.	<b>Schnabel Rep.:</b> M.S.
<b>Location:</b> Takoma Park, Maryland	<b>Date:</b> 8/13/2018
<b>Contract No.:</b> 18C41041	

### Pressuremeter Test Curves

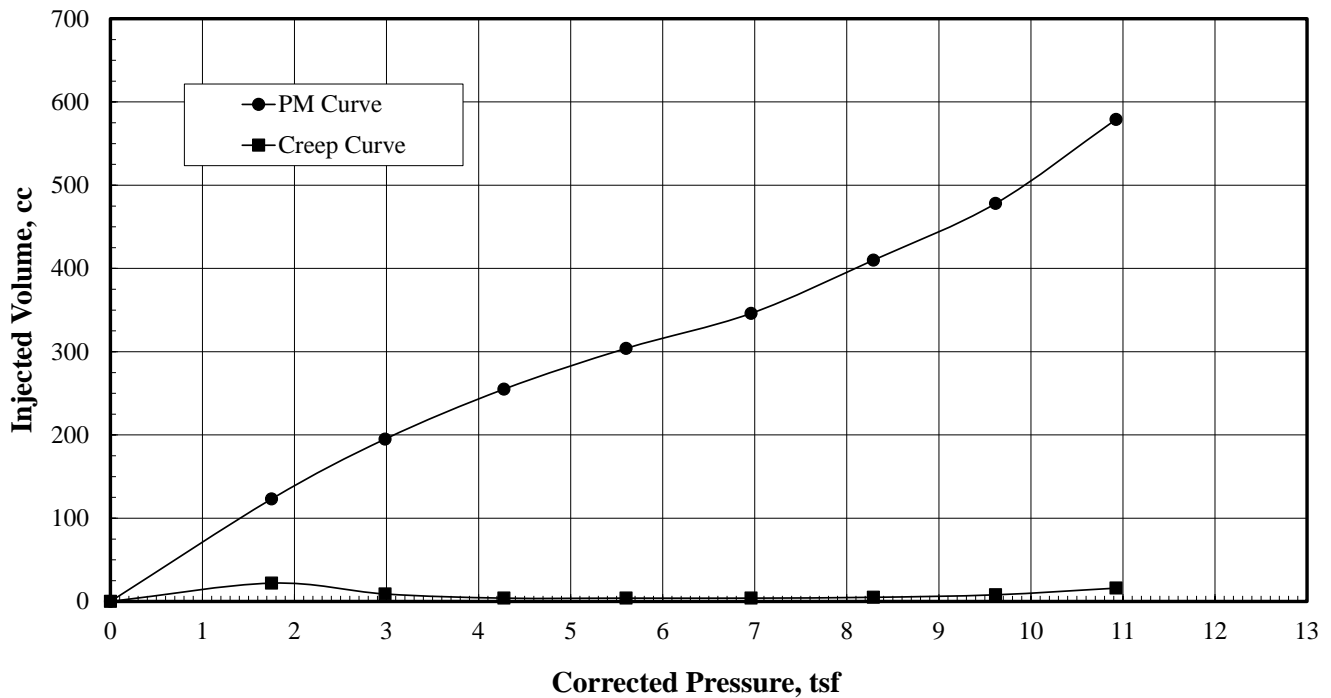

### Pressuremeter Test Data

<b>Boring No.:</b> SB-7	<b>Ground Surface Elevation:</b> 329.4 ft
<b>Test No.:</b> 3	<b>Test Elevation:</b> 305.4 ft
<b>Test Depth:</b> 24	<b>Ground Water Elevation:</b> 305.9 ft

**Soil Description:** Sandy Silt, whitish gray, wet, contains mica

<b>Geology:</b> Residual	<b>Soil Classification:</b> ML
<b>N-Value:</b> 25	

<b>Pressuremeter Modulus:</b> 86 tsf
<b>Estimated Limit Pressure:</b> 12 (Visual Estimate Only)

# Schnabel Engineering

## Pressuremeter Test Results

<b>Project Name:</b> Montgomery Coll. Math and Sci. Bldg.	<b>Schnabel Rep.:</b> M.S.
<b>Location:</b> Takoma Park, Maryland	<b>Date:</b> 8/13/2018
<b>Contract No.:</b> 18C41041	

### Pressuremeter Test Curves

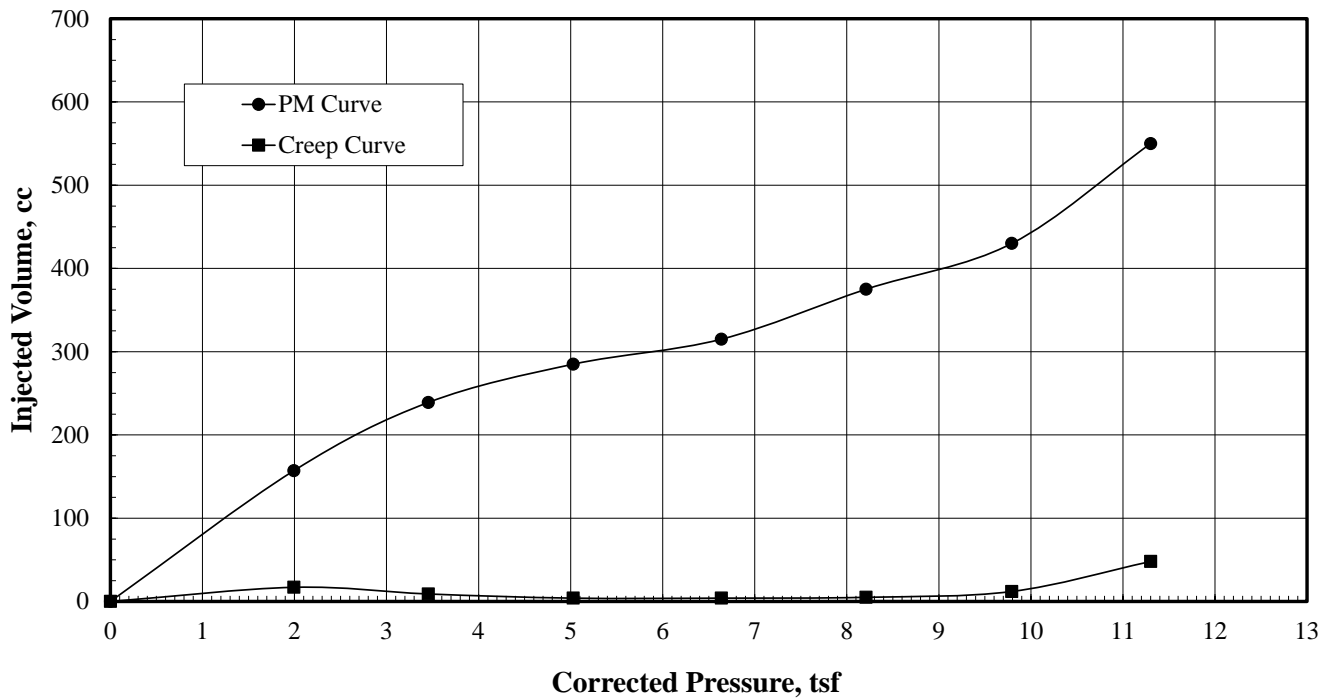

### Pressuremeter Test Data

<b>Boring No.:</b> SB-7	<b>Ground Surface Elevation:</b> 329.4 ft
<b>Test No.:</b> 4	<b>Test Elevation:</b> 301.9 ft
<b>Test Depth:</b> 27.5	<b>Ground Water Elevation:</b> 305.9 ft

**Soil Description:** Sandy Silt, whitish gray, wet, contains mica

<b>Geology:</b> Residual	<b>Soil Classification:</b> ML
<b>N-Value:</b> 31	

<b>Pressuremeter Modulus:</b> 105 tsf
<b>Estimated Limit Pressure:</b> 13 (Visual Estimate Only)



# APPENDIX C

## SOIL LABORATORY TEST DATA

Summary of Laboratory Tests (1 sheet)

Grain Size Distribution (3 sheets)

Atterberg Limits' Results (1 sheet)

USDA Classification (6 sheets)

**CLIENT** The Catherine and Isiah Leggett Building **PROJECT NAME** The Catherine and Isiah Leggett Building

**PROJECT NUMBER** 18C41041 **PROJECT LOCATION** The Catherine and Isiah Leggett Building

Borehole	Depth(ft)	Liquid Limit	Plastic Limit	Plasticity Index	Maximum Size (mm)	Saturation (%)	%<#200 Sieve	Classification	Water Content (%)	Dry Density (pcf)	Void Ratio
SB-1	6-7.5	39	24	15	4.75		83	CL	19.0		
SB-3	1-2.5								17.7		
SB-3	6-7.5								17.0		
SB-3	13.5-15								23.3		
SB-3	23.5-25	47	23	24	4.75		42	SC	29.3		
SB-8	6-7.5	41	23	18	9.5		51	CL	14.5		
SB-8	23.5-25	49	24	25	4.75		56	CL	22.9		
SB-9	2.5-4								9.6		
SB-9	8.5-10	39	25	14	4.75		27	SC	14.7		
SWM-1	6.0-8.0	36	23	13	37.5		16	SC	7.4		
SWM-2	5.0-7.0	34	21	13	9.5		32	SC	13.3		
SWM-3	6.0-8.0	35	21	14	19		26	SC	10.5		
SWM-4	6.0-8.0	46	24	22	19		42	SC	20.9		
SWM-5	6.0-8.0	40	25	15	2		82	CL	12.0		
SWM-6	5.0-7.0	37	22	15	2		28	SC	11.1		

LAB SUMMARY - GINT STD US LAB.GDT - 9/3/18 17:26 - C:\USERS\PUBLIC\DOCUMENTS\BENTLEY\GINT\PROJECTS\THE CATHERINE AND ISIAH LEGGETT BUILDING.GPJ

CLIENT The Catherine and Isiah Leggett Building

PROJECT NAME The Catherine and Isiah Leggett Building

PROJECT NUMBER 18C41041

PROJECT LOCATION The Catherine and Isiah Leggett Building

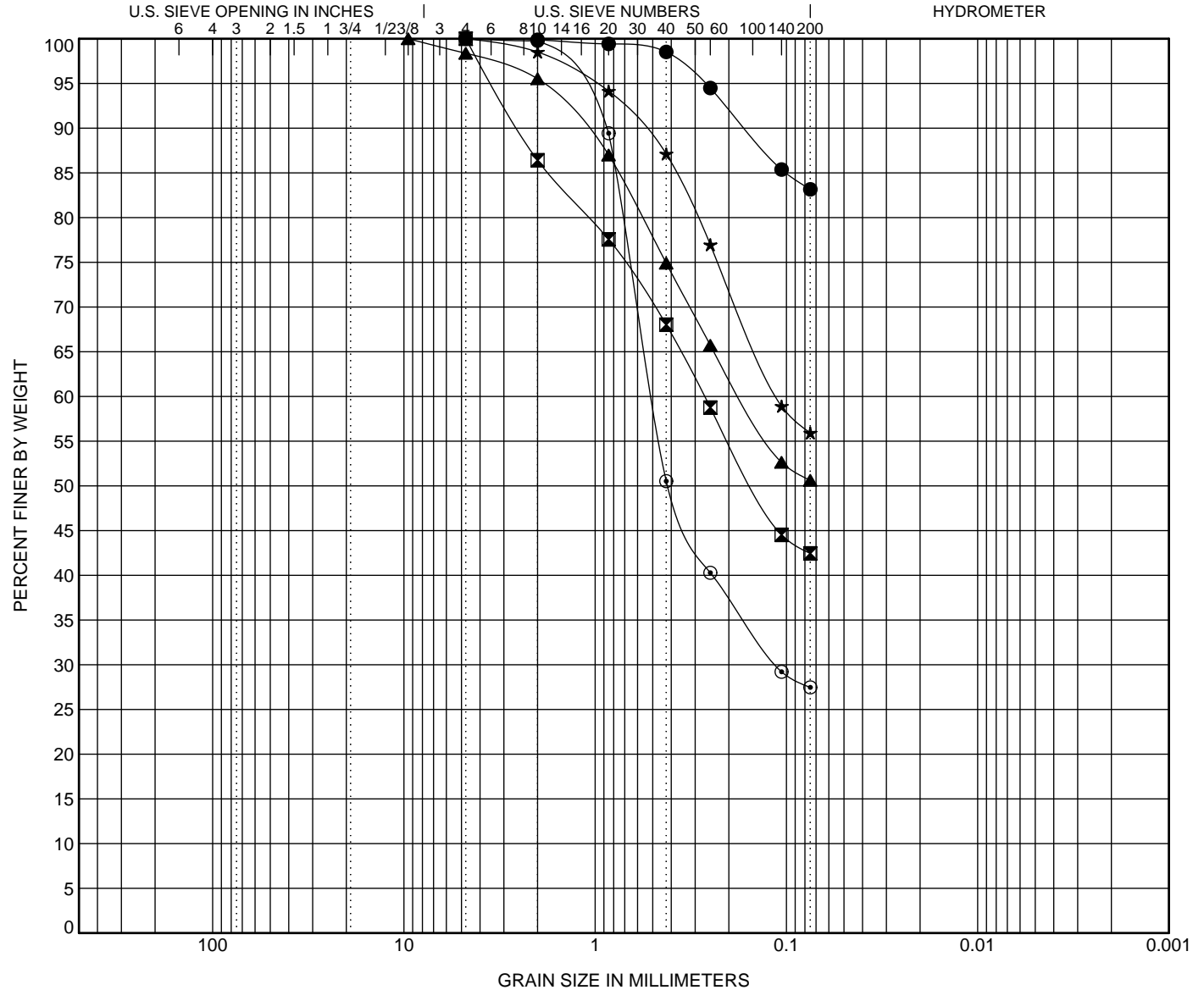

COBBLES	GRAVEL		SAND			SILT OR CLAY
	coarse	fine	coarse	medium	fine	

SAMPLE No.	DEPTH(ft)	Classification	LL	PL	PI	Cc	Cu
● SB-1	6-7.5	LEAN CLAY with SAND(CL), A-6(13)	39	24	15		
■ SB-3	23.5-25	CLAYEY SAND(SC), A-7-6(6)	47	23	24		
▲ SB-8	6-7.5	SANDY LEAN CLAY(CL), A-7-6(6)	41	23	18		
★ SB-8	23.5-25	SANDY LEAN CLAY(CL), A-7-6(11)	49	24	25		
◎ SB-9	8.5-10	CLAYEY SAND(SC), A-2-6(0)	39	25	14		

SAMPLE No.	DEPTH(ft)	D100	D60	D30	D10	%Gravel	%Sand	%Silt	%Clay
● SB-1	6-7.5	4.75				0.0	16.8	83.2	
■ SB-3	23.5-25	4.75	0.269			0.0	57.6	42.4	
▲ SB-8	6-7.5	9.5	0.172			1.6	47.8	50.6	
★ SB-8	23.5-25	4.75	0.112			0.0	44.1	55.9	
◎ SB-9	8.5-10	4.75	0.503	0.113		0.0	72.5	27.5	

GRAIN SIZE - GINT STD. US LAB.GDT - 9/3/18 17:08 - C:\USERS\PUBLIC\DOCUMENTS\BENTLEY\GINT\PROJECTS\THE CATHERINE AND ISIAH LEGGETT BUILDING.GPJ

CLIENT The Catherine and Isiah Leggett Building

PROJECT NAME The Catherine and Isiah Leggett Building

PROJECT NUMBER 18C41041

PROJECT LOCATION The Catherine and Isiah Leggett Building

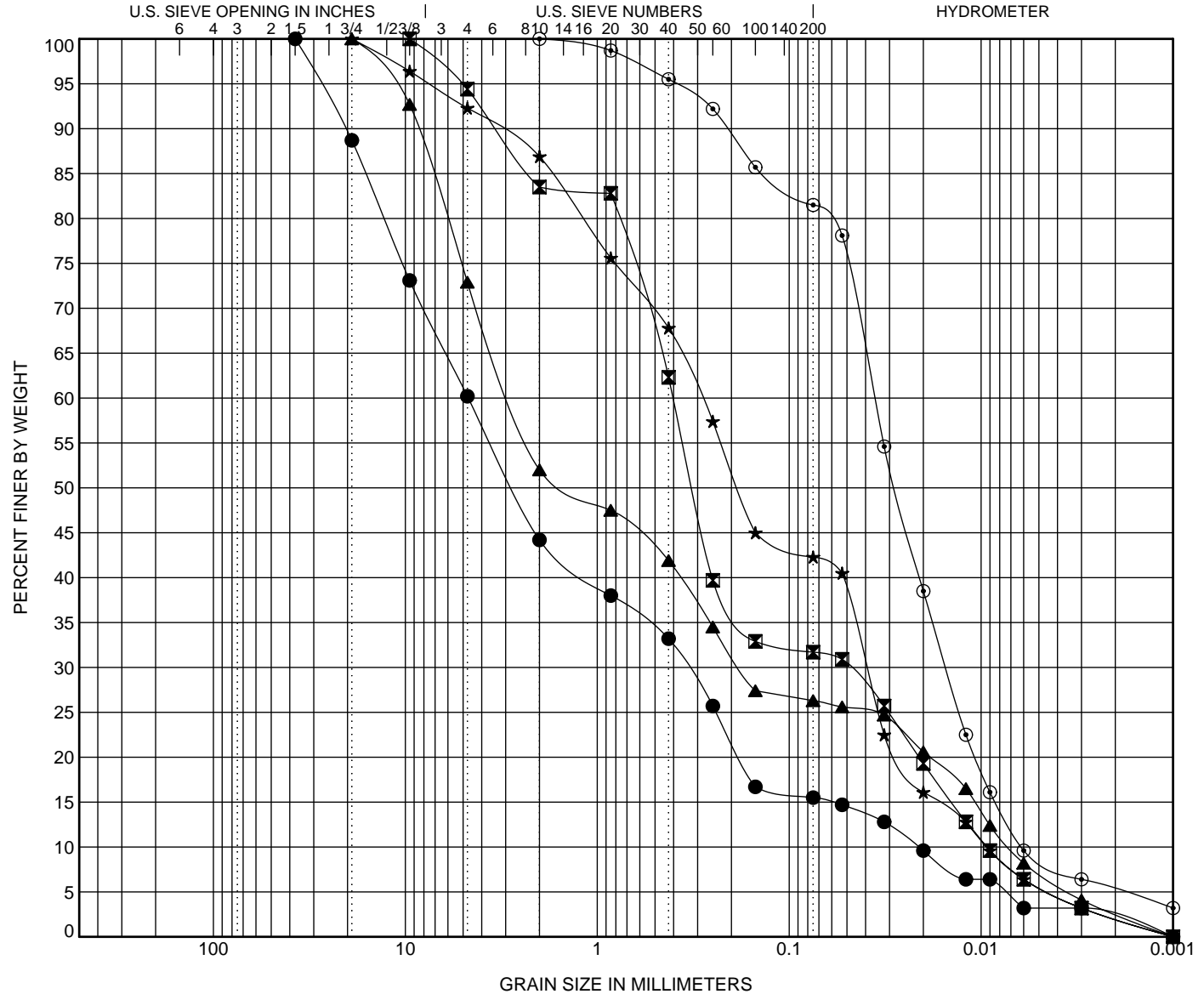

COBBLES	GRAVEL		SAND			SILT OR CLAY
	coarse	fine	coarse	medium	fine	

SAMPLE No.	DEPTH(ft)	Classification	LL	PL	PI	Cc	Cu
● SWM-1	6.0-8.0	CLAYEY SAND with GRAVEL(SC), A-1-b(0)	36	23	13	1.15	221.54
☒ SWM-2	5.0-7.0	CLAYEY SAND(SC), A-2-6(1)	34	21	13	0.63	43.16
▲ SWM-3	6.0-8.0	CLAYEY SAND with GRAVEL(SC), A-2-6(0)	35	21	14	1.65	390.13
★ SWM-4	6.0-8.0	CLAYEY SAND(SC), A-7-6(5)	46	24	22	0.59	30.60
◎ SWM-5	6.0-8.0	LEAN CLAY with SAND(CL), A-6(13)	40	25	15	1.05	5.84

SAMPLE No.	DEPTH(ft)	D100	D60	D30	D10	%Gravel	%Sand	%Silt	%Clay
● SWM-1	6.0-8.0	37.5	4.699	0.339	0.021	39.8	44.7	12.3	3.2
☒ SWM-2	5.0-7.0	9.5	0.403	0.049	0.009	5.6	62.7	26.1	5.6
▲ SWM-3	6.0-8.0	19	2.785	0.181	0.007	27.1	46.6	19.2	7.1
★ SWM-4	6.0-8.0	19	0.285	0.039	0.009	7.7	50.0	36.7	5.6
◎ SWM-5	6.0-8.0	2	0.036	0.015	0.006	0.0	18.5	72.7	8.8

GRAIN SIZE - GINT STD. US LAB.GDT - 9/3/18 17:08 - C:\USERS\PUBLIC\DOCUMENTS\BENTLEY\GINT\PROJECTS\THE CATHERINE AND ISIAH LEGGETT BUILDING.GPJ

CLIENT The Catherine and Isiah Leggett Building

PROJECT NAME The Catherine and Isiah Leggett Building

PROJECT NUMBER 18C41041

PROJECT LOCATION The Catherine and Isiah Leggett Building

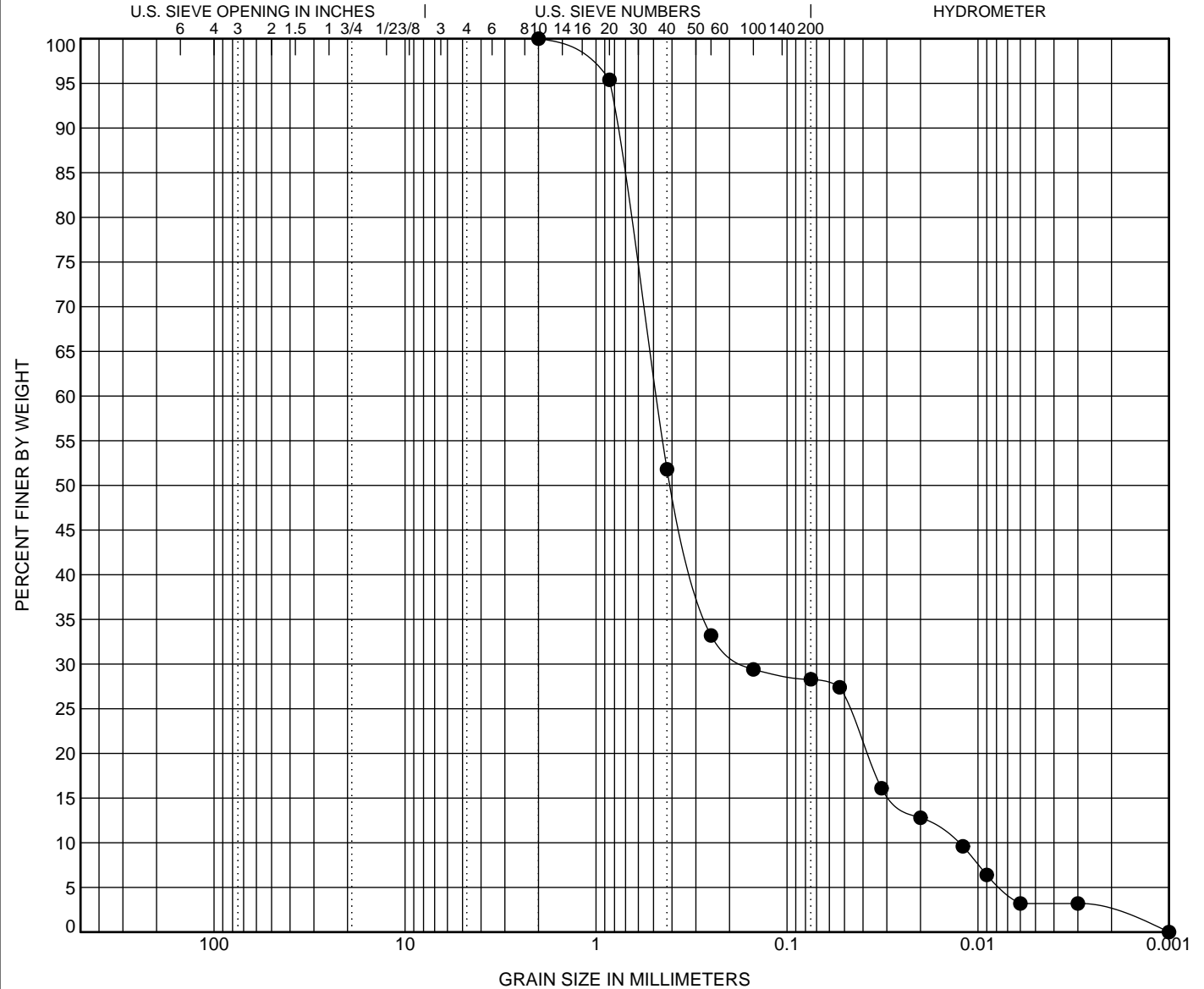

COBBLES	GRAVEL		SAND			SILT OR CLAY
	coarse	fine	coarse	medium	fine	

SAMPLE No.	DEPTH(ft)	Classification	LL	PL	PI	Cc	Cu
● SWM-6	5.0-7.0	CLAYEY SAND(SC), A-2-6(1)	37	22	15	4.27	37.85

SAMPLE No.	DEPTH(ft)	D100	D60	D30	D10	%Gravel	%Sand	%Silt	%Clay
● SWM-6	5.0-7.0	2	0.484	0.163	0.013	0.0	71.7	25.1	3.2

GRAIN SIZE - GINT STD. US LAB.GDT - 9/3/18 17:08 - C:\USERS\PUBLIC\DOCUMENTS\BENTLEY\GINT\PROJECTS\THE CATHERINE AND ISIAH LEGGETT BUILDING.GPJ



<b>USDA Soil Classification</b>	Sandy Loam
---------------------------------	------------

<b>Minimum Infiltration Rate (iph)</b>	1.02
--	------

<b>Hydrologic Soil Grouping</b>	B
---------------------------------	---

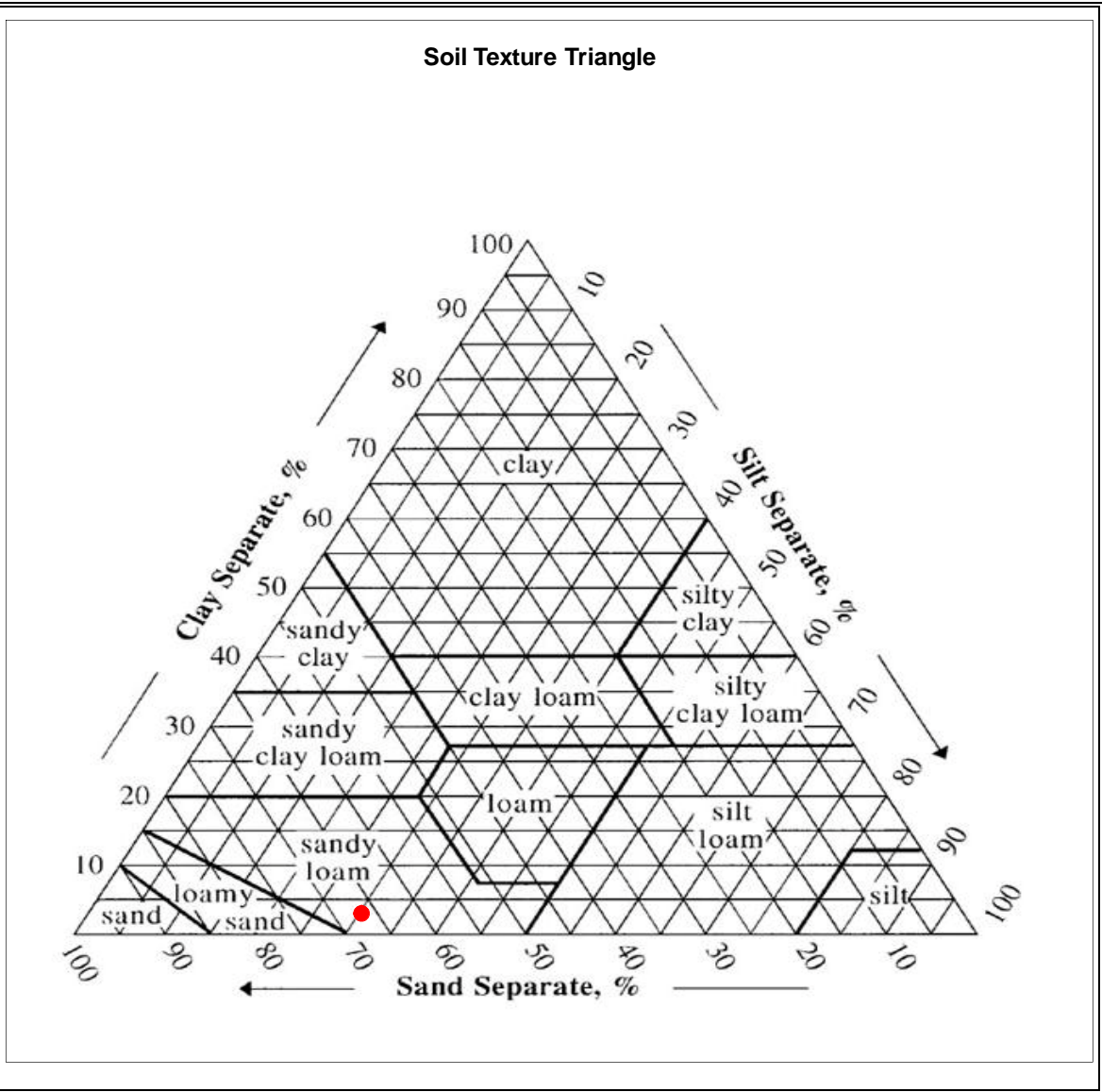

Boring No.	Depth (ft.)	USDA Soil Percentages (corrected for gravel)			Classification
		Sand	Silt	Clay	
SWM-1	6-8	66.7%	30.6%	2.7%	Sandy Loam

<b>Client:</b>	The Catherine and Isiah Leggett Building
<b>Project Name:</b>	The Catherine and Isiah Leggett Building
<b>Project No.:</b>	18C41041
<b>Location:</b>	The Catherine and Isiah Leggett Building
<b>Date:</b>	9/1/18

<b>USDA Soil Classification</b>	Sandy Loam
---------------------------------	------------

<b>Minimum Infiltration Rate (iph)</b>	1.02
--	------

<b>Hydrologic Soil Grouping</b>	B
---------------------------------	---

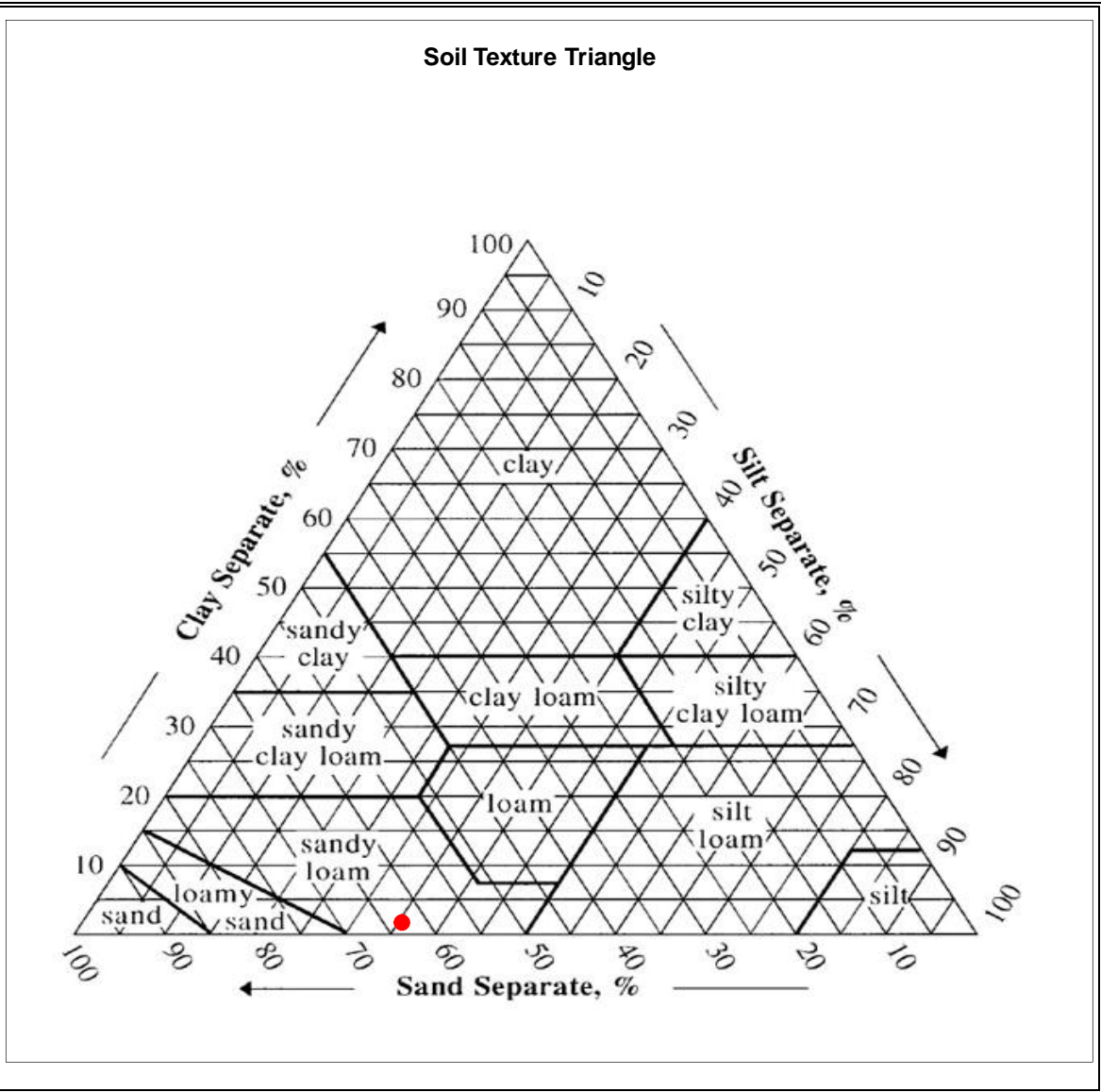

Boring No.	Depth (ft.)	USDA Soil Percentages (corrected for gravel)			Classification
		Sand	Silt	Clay	
SWM-2	5-7	62.9%	35.6%	1.4%	Sandy Loam

<b>Client:</b>	The Catherine and Isiah Leggett Building
<b>Project Name:</b>	The Catherine and Isiah Leggett Building
<b>Project No.:</b>	18C41041
<b>Location:</b>	The Catherine and Isiah Leggett Building
<b>Date:</b>	9/1/18



<b>USDA Soil Classification</b>	Sandy Loam
---------------------------------	------------

<b>Minimum Infiltration Rate (iph)</b>	1.02
--	------

<b>Hydrologic Soil Grouping</b>	B
---------------------------------	---

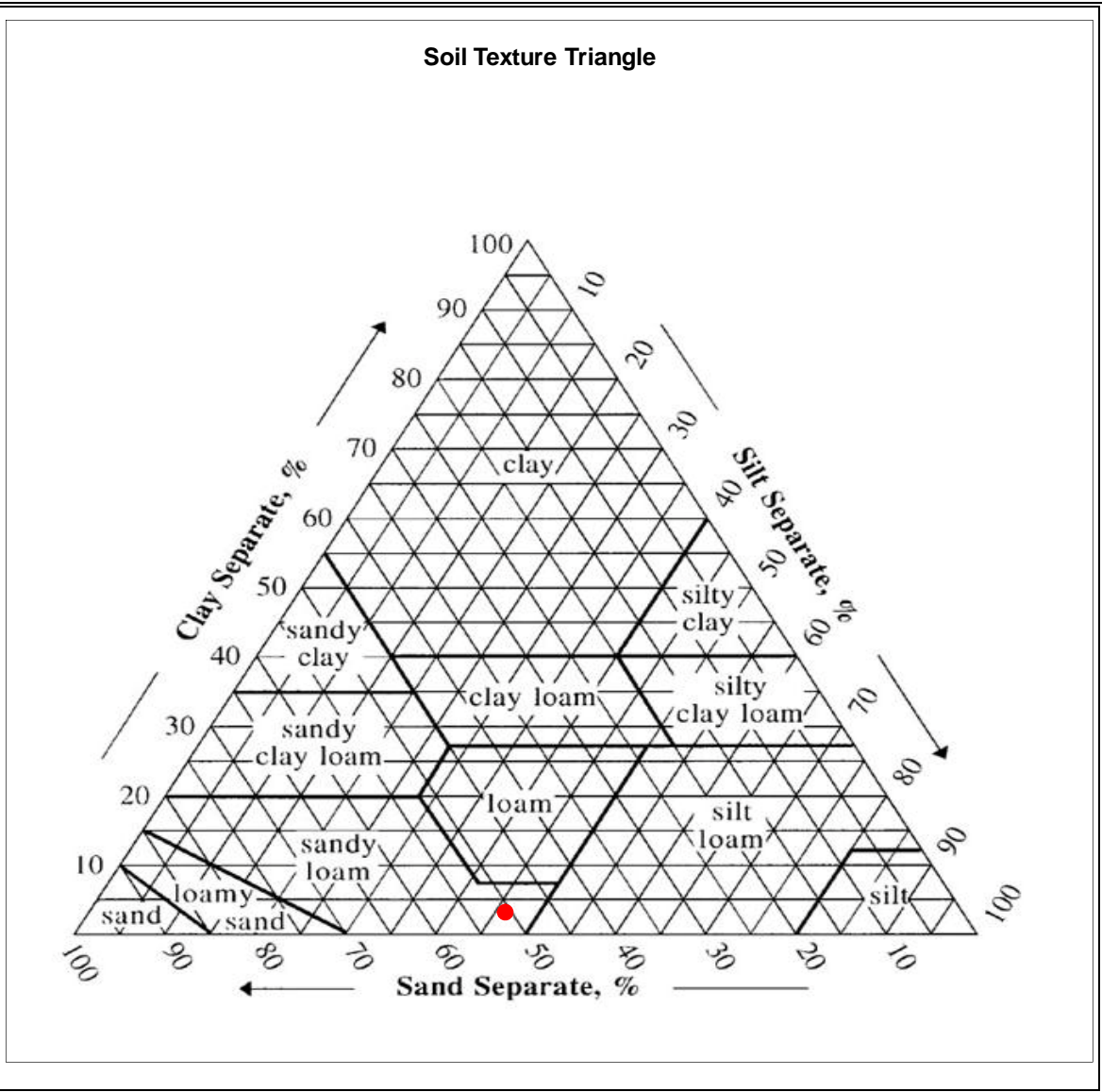

Boring No.	Depth (ft.)	USDA Soil Percentages (corrected for gravel)			Classification
		Sand	Silt	Clay	
SWM-3	6-8	50.7%	46.4%	2.9%	Sandy Loam

<b>Client:</b>	The Catherine and Isiah Leggett Building
<b>Project Name:</b>	The Catherine and Isiah Leggett Building
<b>Project No.:</b>	18C41041
<b>Location:</b>	The Catherine and Isiah Leggett Building
<b>Date:</b>	9/1/18

<b>USDA Soil Classification</b>	Sandy Loam
---------------------------------	------------

<b>Minimum Infiltration Rate (iph)</b>	1.02
--	------

<b>Hydrologic Soil Grouping</b>	B
---------------------------------	---

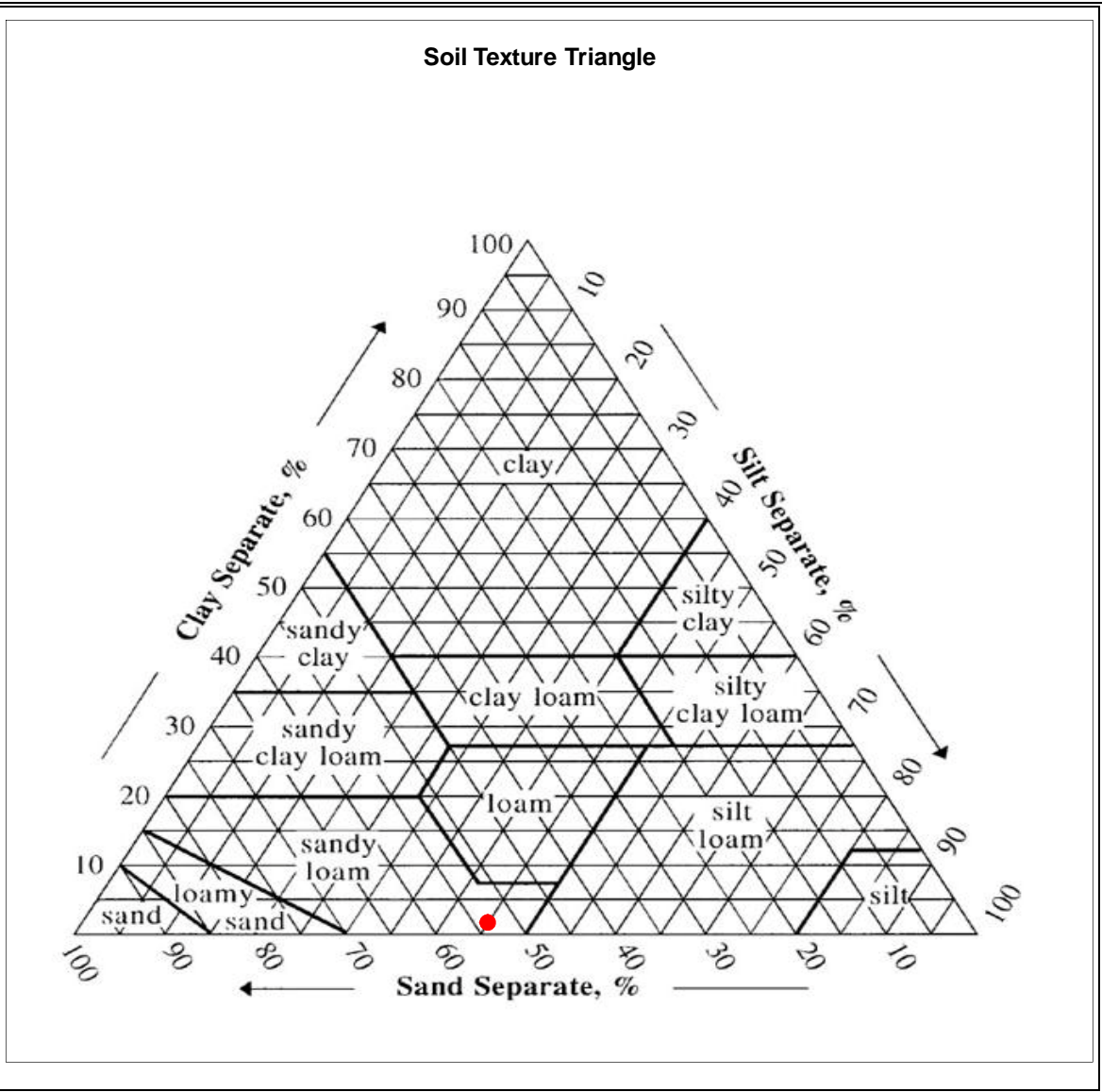

Boring No.	Depth (ft.)	USDA Soil Percentages (corrected for gravel)			Classification
		Sand	Silt	Clay	
SWM-4	6-8	53.4%	45.2%	1.4%	Sandy Loam

<b>Client:</b>	The Catherine and Isiah Leggett Building
<b>Project Name:</b>	The Catherine and Isiah Leggett Building
<b>Project No.:</b>	18C41041
<b>Location:</b>	The Catherine and Isiah Leggett Building
<b>Date:</b>	9/1/18

<b>USDA Soil Classification</b>	Silt Loam
---------------------------------	-----------

<b>Minimum Infiltration Rate (iph)</b>	0.27
--	------

<b>Hydrologic Soil Grouping</b>	C
---------------------------------	---

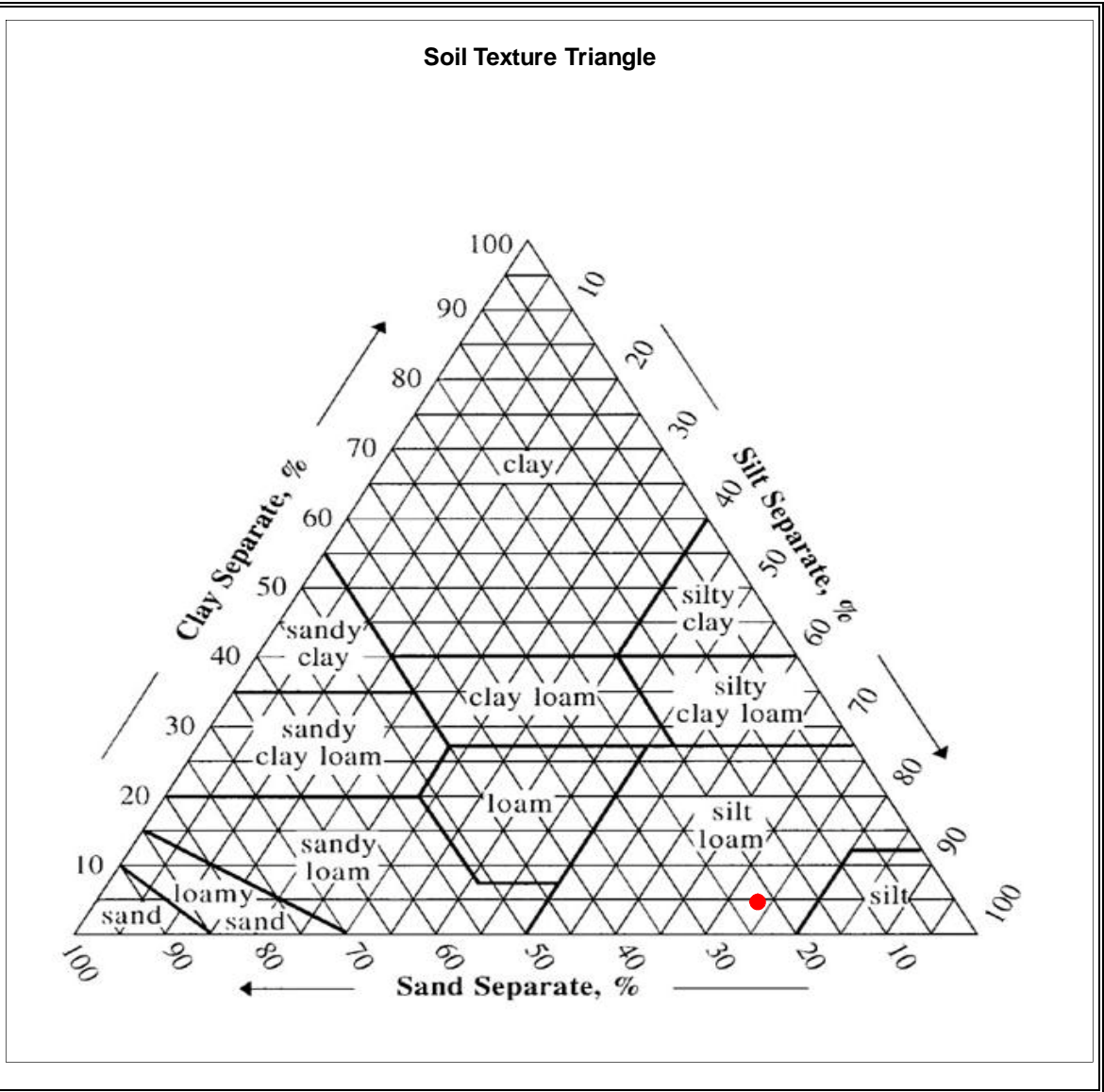

Boring No.	Depth (ft.)	USDA Soil Percentages (corrected for gravel)			Classification
		Sand	Silt	Clay	
SWM-5	6-8	21.9%	73.7%	4.4%	Silt Loam

<b>Client:</b>	The Catherine and Isiah Leggett Building
<b>Project Name:</b>	The Catherine and Isiah Leggett Building
<b>Project No.:</b>	18C41041
<b>Location:</b>	The Catherine and Isiah Leggett Building
<b>Date:</b>	9/1/18

<b>USDA Soil Classification</b>	Loamy Sand
---------------------------------	------------

<b>Minimum Infiltration Rate (iph)</b>	2.41
--	------

<b>Hydrologic Soil Grouping</b>	A
---------------------------------	---

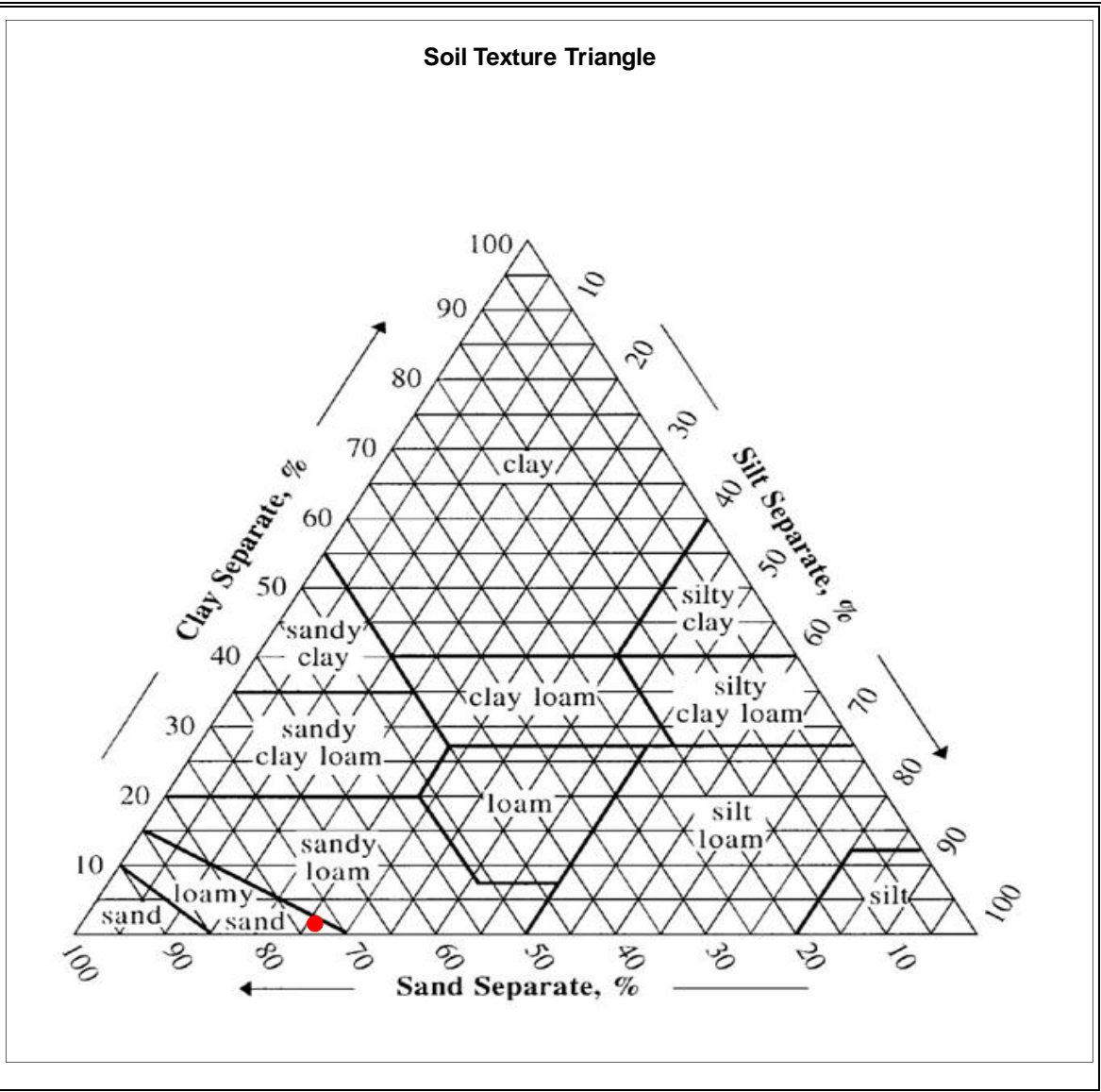

Boring No.	Depth (ft.)	USDA Soil Percentages (corrected for gravel)			Classification
		Sand	Silt	Clay	
SWM-6	5-7	72.6%	26.2%	1.2%	Loamy Sand

<b>Client:</b>	The Catherine and Isiah Leggett Building
<b>Project Name:</b>	The Catherine and Isiah Leggett Building
<b>Project No.:</b>	18C41041
<b>Location:</b>	The Catherine and Isiah Leggett Building
<b>Date:</b>	9/1/18